

spit up & *stilettos*

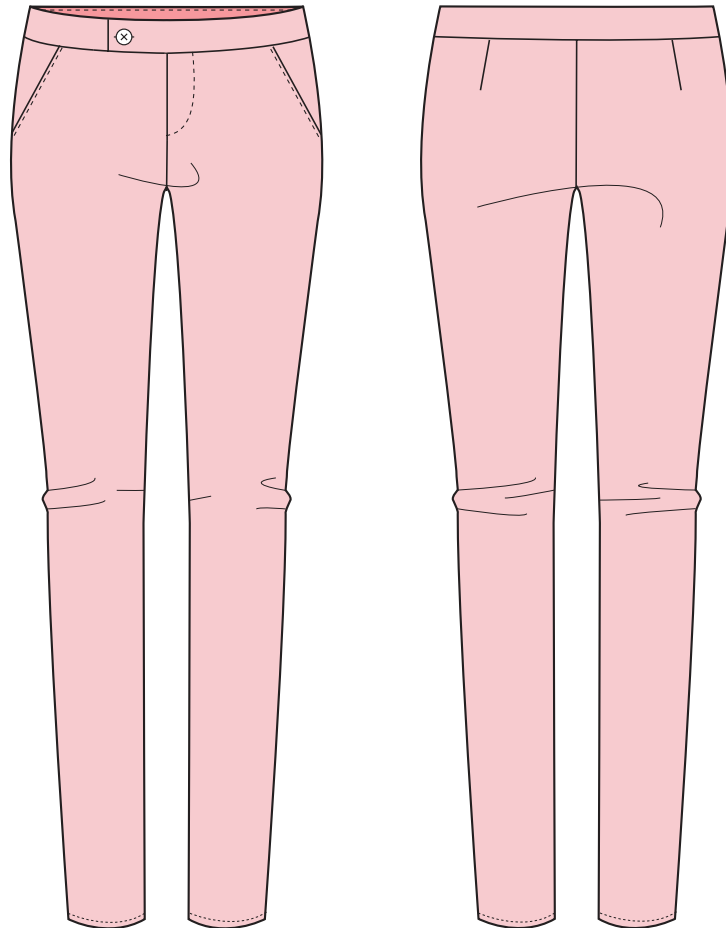

EMMA PANT

Level: Medium | Time: 2-3 Hour | Pages: 43

This mid-rise pant is slim fit and hits just at the ankles. You won't believe how versatile, comfy and chic these are. Front button closure and slash front pockets are perfect for your cell phone and lipstick. Find fabric that is medium or pant weight twill with some stretch.

Copyright 2014 Spitupandstilettos.com All Rights Reserved

Size Chart

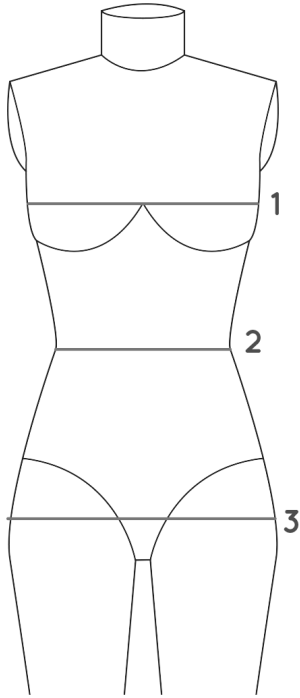

Size	Numeric Size	Bust	Waist	Hips
XS	0	33"	25"	35"
XS	2	34"	26"	36"
S	4	35"	27"	37"
S	6	36"	28"	38"
M	8	37"	29"	39"
M	10	38"	30"	40"
L	12	39.5"	31.5"	41.5"
L	14	41"	33"	43"
XL	16	43"	35"	45"
XL	18	45"	37"	47"

(1) BUST: Measure around the fullest part of your bust and keep the measuring tape parallel to the floor.

(2) WAIST: Measure around the smallest part of your waist.

(3) HIP: Measure around the fullest part of your hip and keep the measuring tape parallel to the floor.

Supplies

- Fabric
- Interfacing
- Thread
- 1 Size 30 (3/4") button OR pant hook & eye
- 1 5-7" Polyester zipper

Tools

- Fabric scissors
- Pins
- Chalk or marking pen
- Tape (for piecing pattern)
- Paper scissors (to cut pattern)

Fabric

Find medium weight twill or pant weight fabric with stretch. If you want a fun colored pocket bag, cut the front and back bag pieces from another fabric.

Fabric Usage

45" WIDE

You will need 2 3/4 yards of fabric. If you are doing a stripe or plaid pant, you will need an extra 1/2 to 1 yard of fabric. Below is the layout guide.

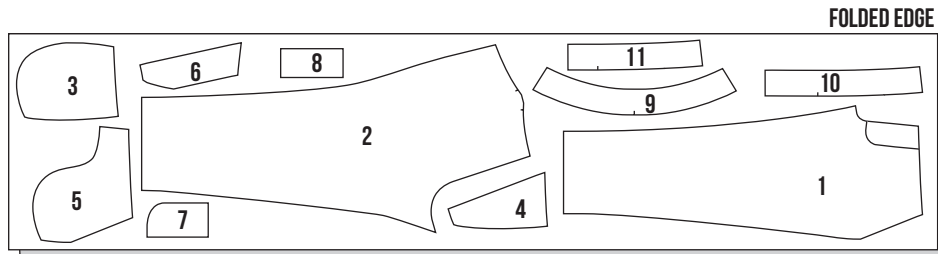

60" WIDE

You will need 2 yards of fabric. If you are doing a stripe or plaid pant, you will need an extra 1/2 to 1 yard of fabric. Below is the layout guide.

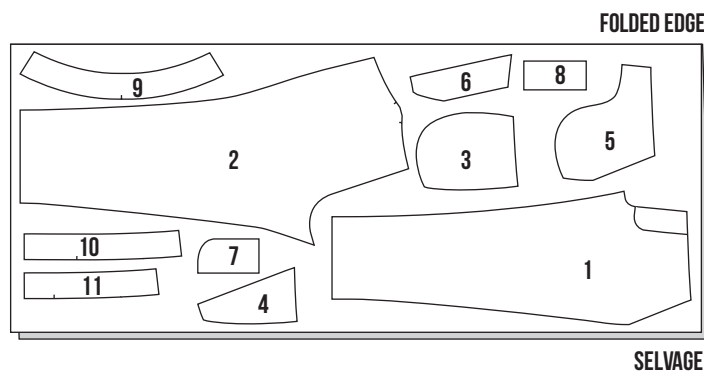

INTERFACING

You will need 3/4 yards of interfacing that is a similar weight to your main fabric. Interfacing that is too stiff will change the shape of your garment, which is bad! Below is the layout guide for 20" wide interfacing.

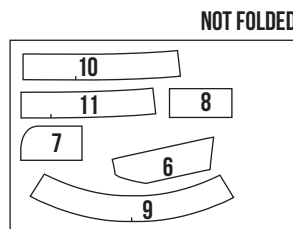

Why is there only one fabric usage guide? Well, we felt that to make things easier we would only include one based on the largest size so that no matter what you have enough fabric. Who doesn't love scraps?

First Things First

FIND YOUR SIZE

Using the size chart on the previous page, find your size. If you are in between, you can draw a new pattern line between the two sizes or simply choose the larger size.

PIECE TOGETHER YOUR PATTERN

At the end of these instructions, you will find your PDF pattern. On the first page, there is a 2" x 2" test square. Measure this square with a ruler to verify that the pattern is the correct size and then cut out each 7" x 9.5" rectangle. Tape the pieces together matching the colors/letters/numbers, then cut out your pattern size.

LAY OUT YOUR PATTERN

Using the fabric layout in the Fabric Usage section as a guide, lay out your pattern pieces. Use either pins or pattern weights (we like the latter option) to keep your pattern in place. Pay attention to the fabric grainline and, if using a plaid or stripe fabric, make sure to line up the stripes.

TRACE THE PATTERN

Trace your pattern edges onto your fabric by using chalk, pencil, or carbon paper. Transfer all markings, notches, darts and center front and back lines. Trust us. It's really no fun to have to come back and mark them later.

CUT IT OUT

You know that pattern tracing you just did? Well, cut along your marking lines.

SEAM ALLOWANCE

This pattern includes 5/8" seam allowances unless otherwise stated. Don't worry, we will let you know in the instructions when you're sewing a piece with a different seam allowance.

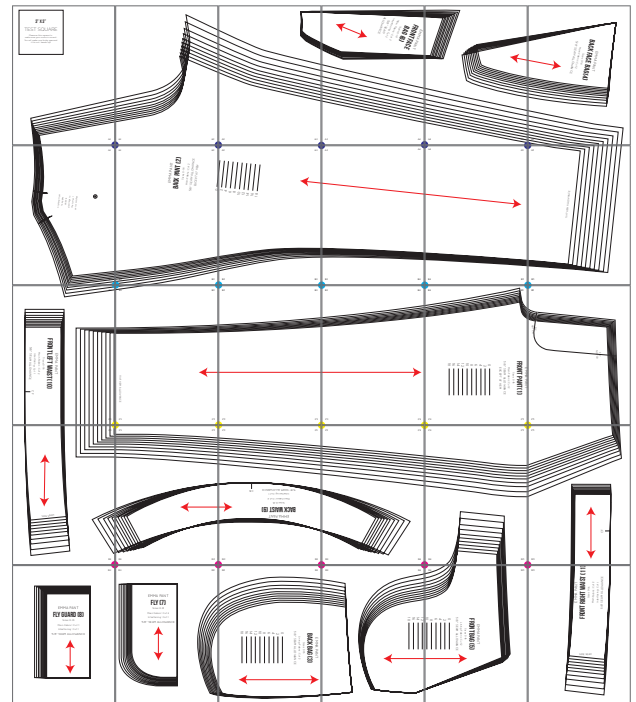

.....
• If this is your first time making this pattern, it's always a good idea to make a muslin to test the fit and make sure it flatters your body type. A muslin also lets you know what areas need to be altered. For a quick alteration guide or if you have any fit questions, go to Spitupandstilettos.com
.....

Pattern Key

GRAINLINE

This red arrow indicates your grainline, which you should align with the grain of your fabric. Don't know what grainline or grain is? Let us explain. When fabric is made it is woven with threads that go in two different directions. Lengthwise, which spans the cut edges and crosswise, which spans the selvage edges (the selvage is the band of tightly woven fabric that runs up either side). The lengthwise direction is the grain of your fabric and what you use to line up your grainline.



FOLD LINE

This means you line up the edge with the folded edge of your fabric before you cut.



NOTCH

Mark this onto your fabric with chalk, washable pen, or carbon paper to use for future reference.

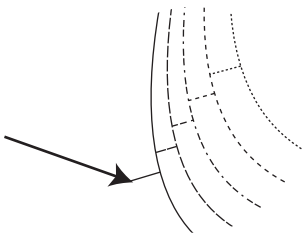

BUTTONHOLE PLACEMENT

This indicates where a button (left image) and buttonhole (right image) will go.



Staystitch

1. Start off by staystitching the waistline just inside the seam allowance on all pieces.

TIDBIT: Stay stitching prevents curves from stretching out, and should be sewn within your seam allowance (not on the stitch line).

Darts

1. Draw in dart legs by connecting the match point and dart notches.
2. On **BACK PANT**, stitch together darts by pinning together dart legs and starting from the edge stitch toward the dart tip.
3. At the dart tip, sew off the end without backstitching and tie the thread tails together.
4. Press the darts toward center back.

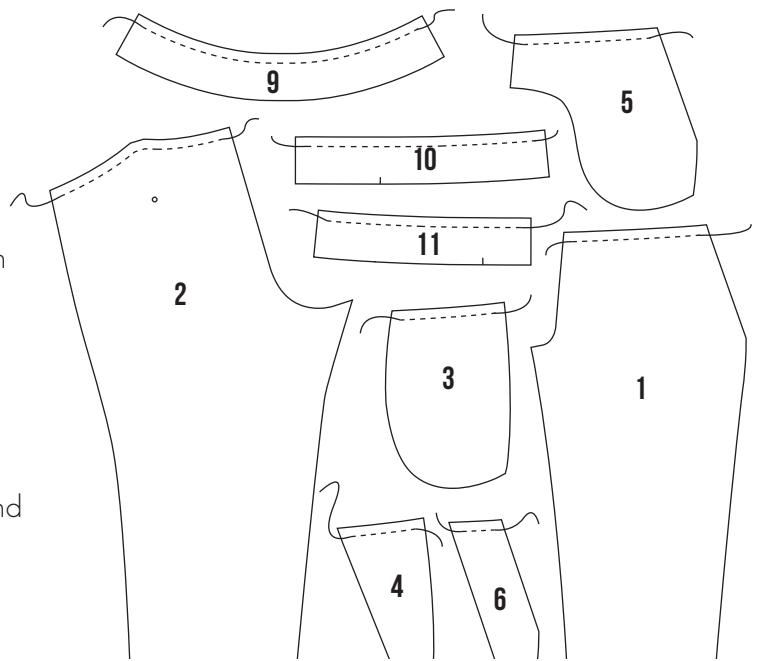

Front Bag

1. Attach interfacing to **FRONT FACE BAG** pieces by pressing for 15 seconds. Make sure the glue adhesive is face down to fabric. The fusible should be attached on the wrong side of the fabric.
2. Press back the seam allowance (5/8") on the left edge of the **FRONT FACE BAG**. Trim down the extending seam allowance at the top.
3. Line up **FRONT FACE BAG** with **FRONT BAG** piece right sides up and pin.
4. Edge stitch 1/16" away from the folded edge of **FRONT FACE BAG** to attach it to the **FRONT BAG**, then press.

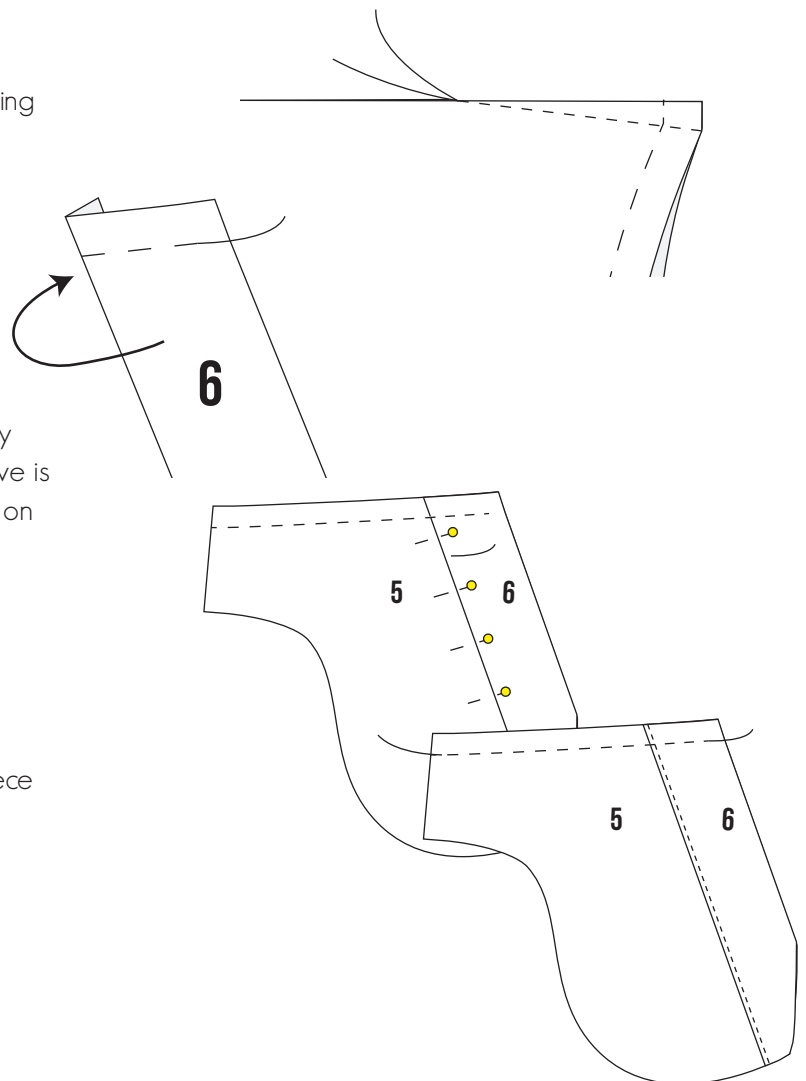

Instructions Page 2

Back Bag

1. Press back the seam allowance on the inside edge of the BACK FACE BAG. Trim down the extending seam allowance at the top.
2. Line up BACK FACE BAG with BACK BAG piece right sides up and pin.
3. Edge stitch $1/16$ " away from the folded edge of BACK FACE BAG to attach it to the BACK BAG, then press.

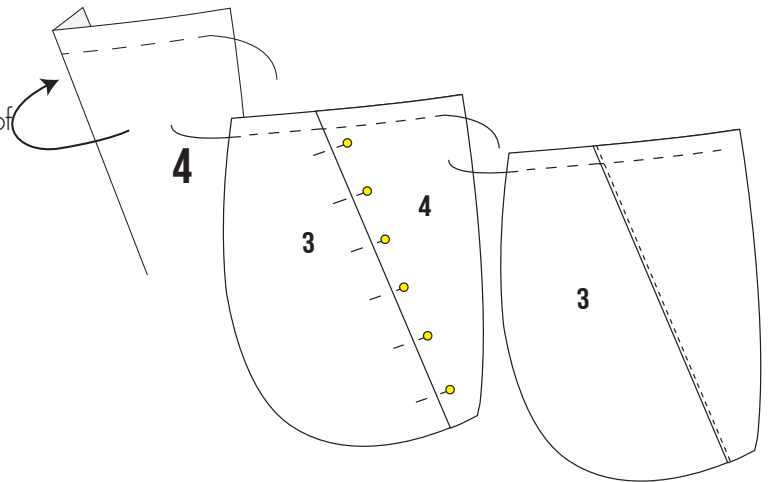

Pockets

TIDBIT: You can finish the curved edges of the pocket bag for a more professional finish. Common finishes are zig-zag, overcast, overlock, or pinking.

1. Line up and pin the pocket edge on FRONT PANT with the pocket edge of FRONT BAG, right sides together.
2. Stitch seam along the pocket edge (seam allowance is $5/8$ ").
3. Press seam open, then fold pieces wrong side together and press seam flat.
4. Topstitch along the pocket edge. You may need to trim down the seam allowance underneath if you notice bulk.
5. Line up the FRONT BAG and BACK BAG pieces.
6. Stitch along the curved edge of the BACK BAG to attach the bag pieces together (do not stitch though to FRONT PANT).
7. Press the FRONT PANT pocket area flat, and pin all pieces together along the waistline. Stitch all pieces together along waistline.
8. Make a bar tack 1 " down from waistline along the pocket edge.

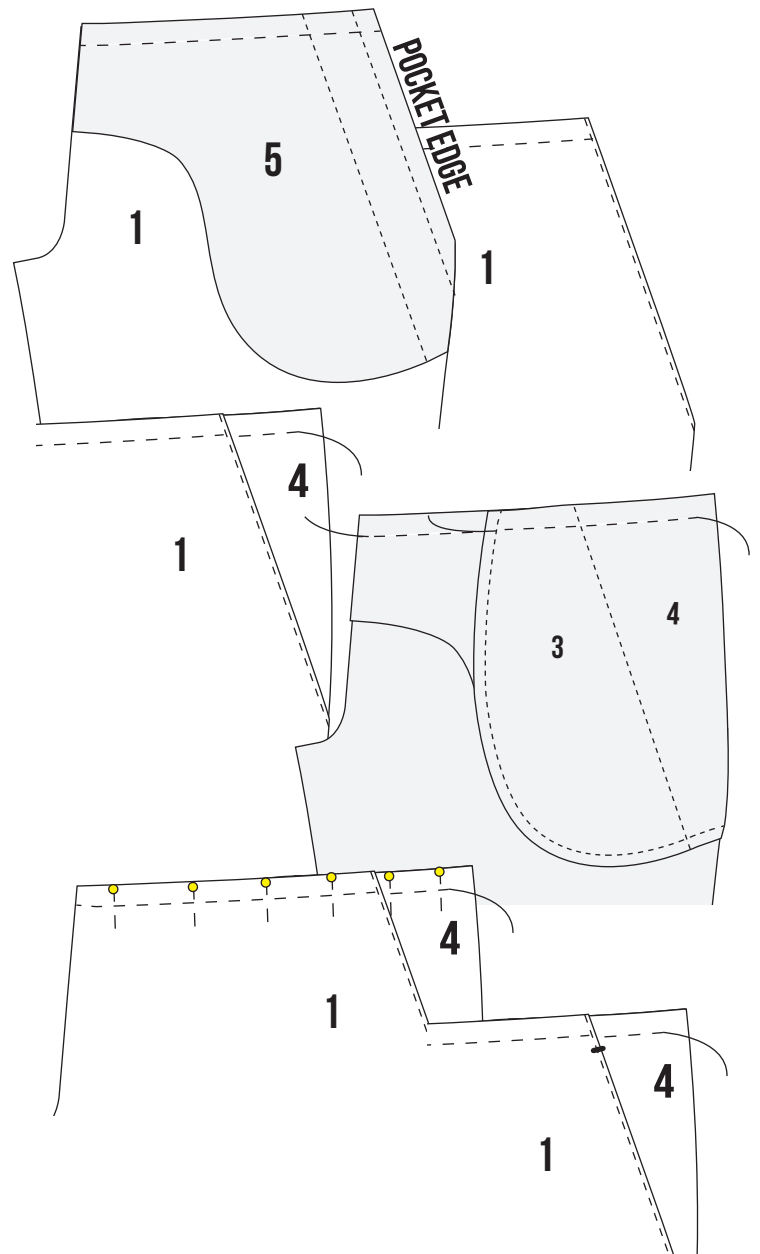

Outseams

1. Line up right sides together the FRONT PANT and BACK PANT pieces along the outside side seam, pinning as you go. Make sure the pocket lays flat.
2. Join your pieces together by stitching along your side seam.
3. Press your seam open and finish your seams as you choose. You may need to reduce seam allowance bulk.
4. Make a bar tack at the intersection of the side seam and pocket opening.

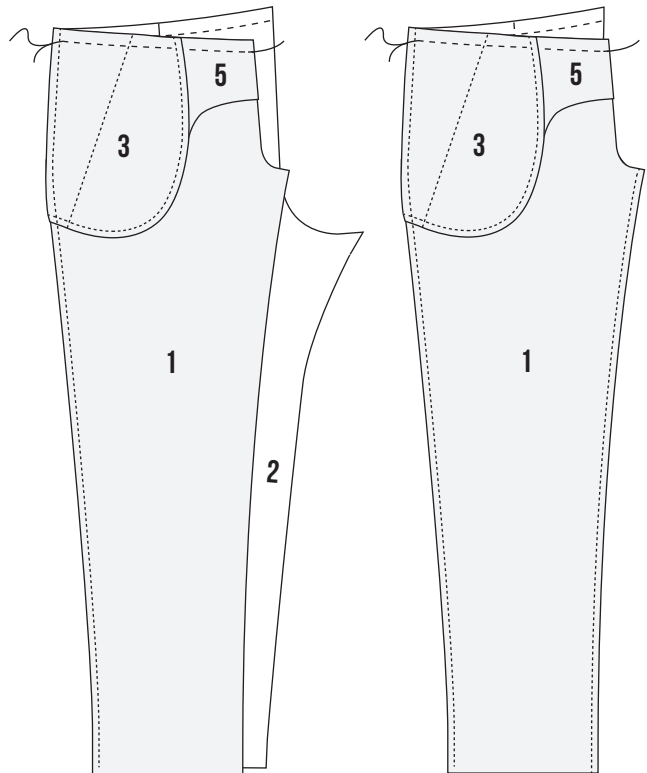

Inseams

1. Line up right sides together the FRONT PANT and BACK PANT pattern pieces along the inside side seam, pinning as you go.
2. Join your pieces together by stitching along your side seam.
3. Press your seam open and finish your seams as you choose. You may need to reduce seam allowance bulk.

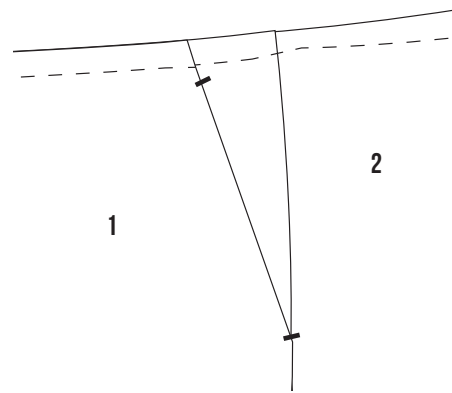

Fly Guard

1. Fuse your FLY GUARD interfacing piece onto your FLY GUARD piece by pressing for 15 seconds. Make sure the glue adhesive is face down to fabric. Finish the edges now if you'd like.
2. Take the FLY GUARD and line it up with the front RIGHT PANT at center front (right sides together). Stitch along seam line.
3. Press open, then top stitch 1/16" from the fly guard edge, catching the seam allowance underneath.

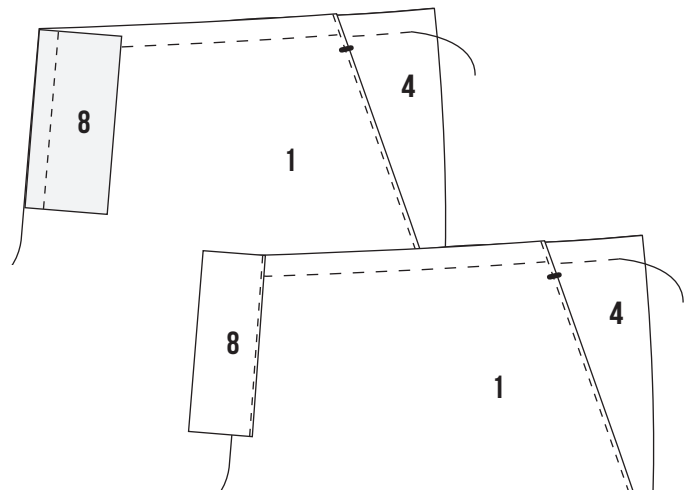

Crotch Seam

1. Line up PANT crotches, making sure to pin along the curve. Stitch the full length of the crotch starting at the fly notch.
2. Press seam open, and press back the seam allowance on center front to 1/2". Finish your seams to your liking.

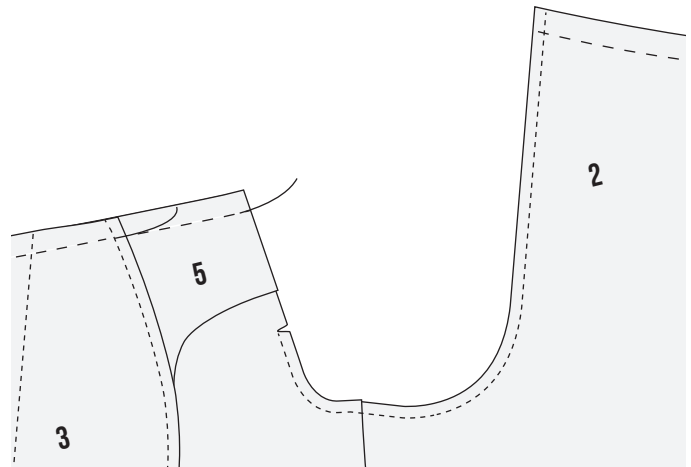

Fly

1. Fuse your FLY interfacing piece onto your right FLY fabric piece by pressing for 15 seconds. Make sure the glue adhesive is face down to fabric. The fusible should be attached on the wrong side of the fabric.
2. Line up your FLY pieces face sides together, and stitch along the curved edge.
3. Trim down and notch along the seam allowance to reduce bulk.
4. Press open, then turn right side out and press flat.
5. Top stitch along the press edge.

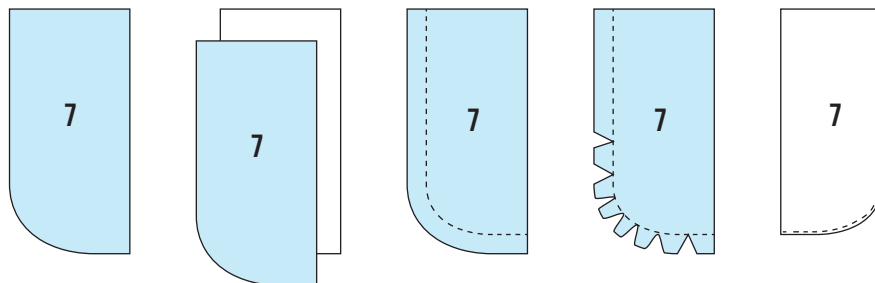

Instructions Page 5

Zipper

NOTE: Zipper tape usually has a seam allowance of $\frac{3}{8}$ " , and since your seam allowance is $\frac{5}{8}$ " you cannot merely line up edges.

1. Lay your zipper face up on your FLY piece, then align the left zipper tape along the seam line. The zipper teeth should extend into the FLY piece by $\frac{1}{8}$ ". Make sure the zipper top ends exactly at the top seam line.

2. Lay the left center front PANT edge on top of the zipper so that it hides the tape, but so the teeth are still exposed. (You pressed back the seam allowance to $\frac{1}{2}$ " earlier, remember?)

3. Make sure all layers are aligned, and then pin.

4. Topstitch through all layers along center front, until you're where the crotch seam begins.

5. Flip to the wrong side and pin the other zipper tape to the FLY GUARD (don't pin to the pant!) The zipper teeth should be $\frac{1}{4}$ " from the edge. Stitch along the zipper teeth edge (don't sew through to the pant!).

6. Make sure when zipped, the zipper is hidden by the FLY and the top edges line up.

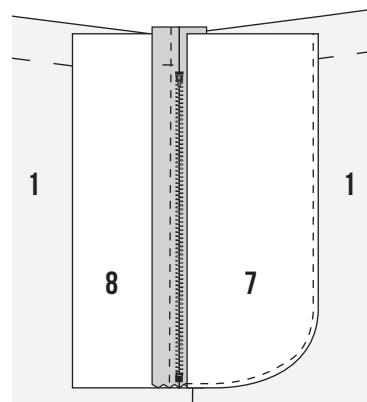
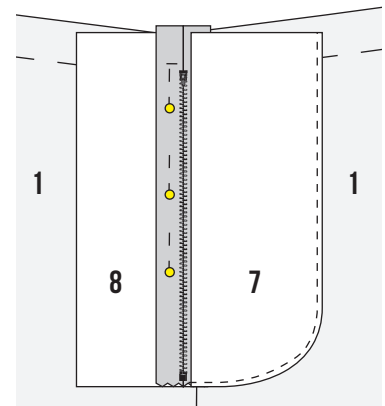
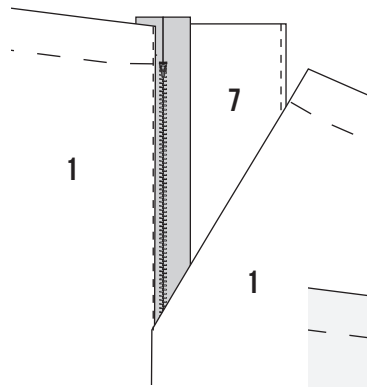
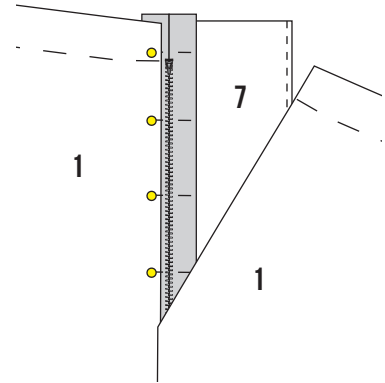
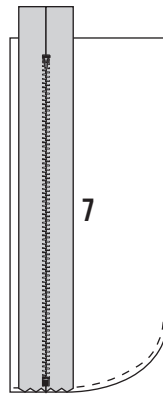

Instructions Page 6

J-Topstitching

1. Press flat the front right pant, and mark with chalk or pen your "J" topstitching line using the fly notches as a guide.
2. Starting at the seam allowance edge, fold the FLY out of the way and top stitch your "J" catching the FLY GUARD underneath.
3. Backtack a couple times at the end to secure and give the seam strength. Make sure your zipper is closed, fold back your FLY then find the bottom edge where the FLY and FLY GUARD overlap. Pin.
4. Make a securing stitch where your pin is to attach the FLY and FLY GUARD.

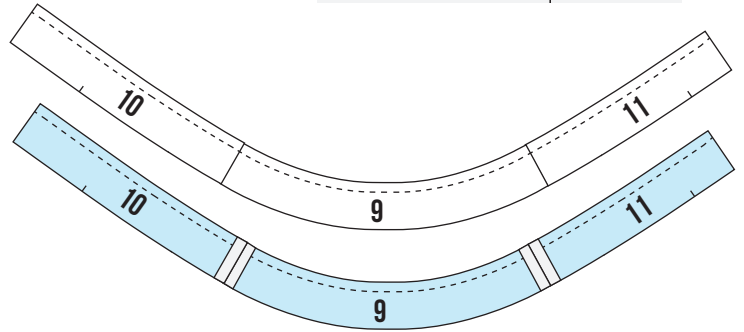
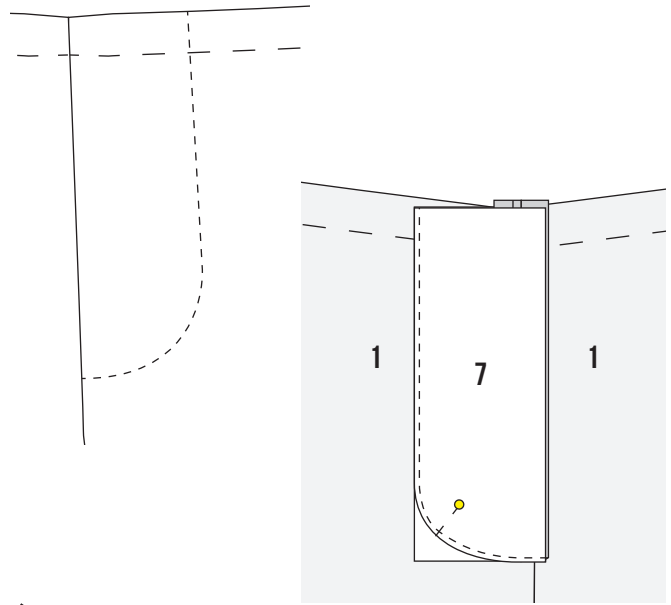

Waistband

1. Fuse your WAISTBAND interfacing pieces onto the first set of the WAISTBAND pieces by pressing for 15 seconds in each place. Make sure the glue adhesive is face down to fabric.
2. Line up the side seams on each set of waistband pieces and stitch together.
3. Line up the waistbands face side together and stitch along the top edge. Trim down seam allowance to 1/4" and notch.
4. Under stitch 1/16" from edge along the top edge of the WAISTBAND on the interfacing side. Catch the seam allowance underneath.
5. Line up the waist seams of the WAISTBAND and PANT pieces right sides together, pin along the way.
6. Sew the WAISTBAND and PANT together along the waist and then reduce seam allowance to 1/4".

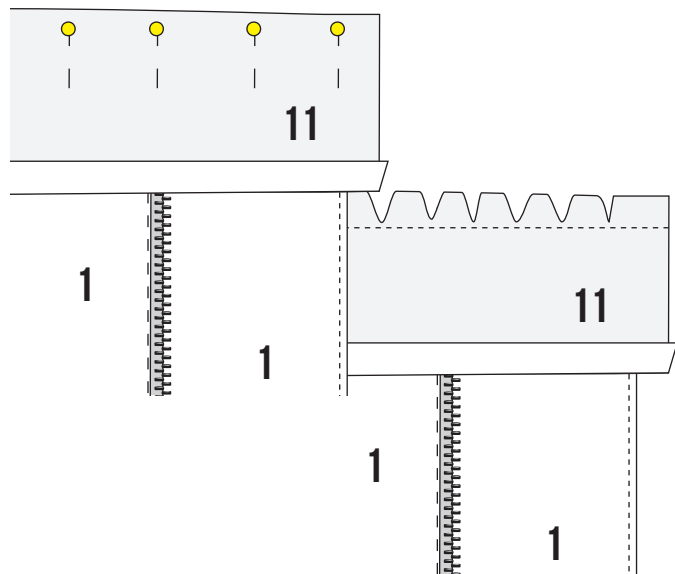
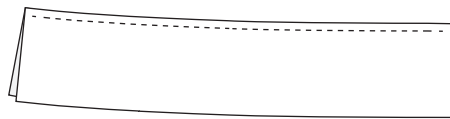

Waistband Finishing

1. Fold waistband in half lengthwise, right sides together and stitch the ends closed. On the extended waistband, sew the bottom edge closed but stop at center front. Reduce the corner bulk by notching, then turn your waistband right side out. Press flat.
2. Press the waistband seam allowance up into the waistband. This will be your last chance to reduce bulk in the seam allowance!
3. Overlock or zig-zag stitch along the exposed waistband edge to finish.
4. Pin the waistband flat, then stitch in the ditch on the face side of the garment along the waistline seam, starting at center front.

TIDBIT: When you stitch along a seam it is called 'stitching in the ditch' and is commonly used on waistbands. Stitching in the ditch makes the stitching thread less obvious.

Buttonhole

You can either have your pants close with a button or pant hook and eye (perhaps both if you want extra reinforcement at center front).

1. On the extended waistband edge, measure in 1/2" and then mark your 5/8" buttonhole opening with chalk or a pen. Center the buttonhole between the waistband edges.
2. Go over to your sewing machine and stitch your buttonhole using either your buttonhole foot or straight stitch. For the buttonhole foot, check your sewing machine manual to see how yours works. If using a straight stitch, remember to backtack the top and bottom edges for reinforcement.
3. Cut your buttonhole open.

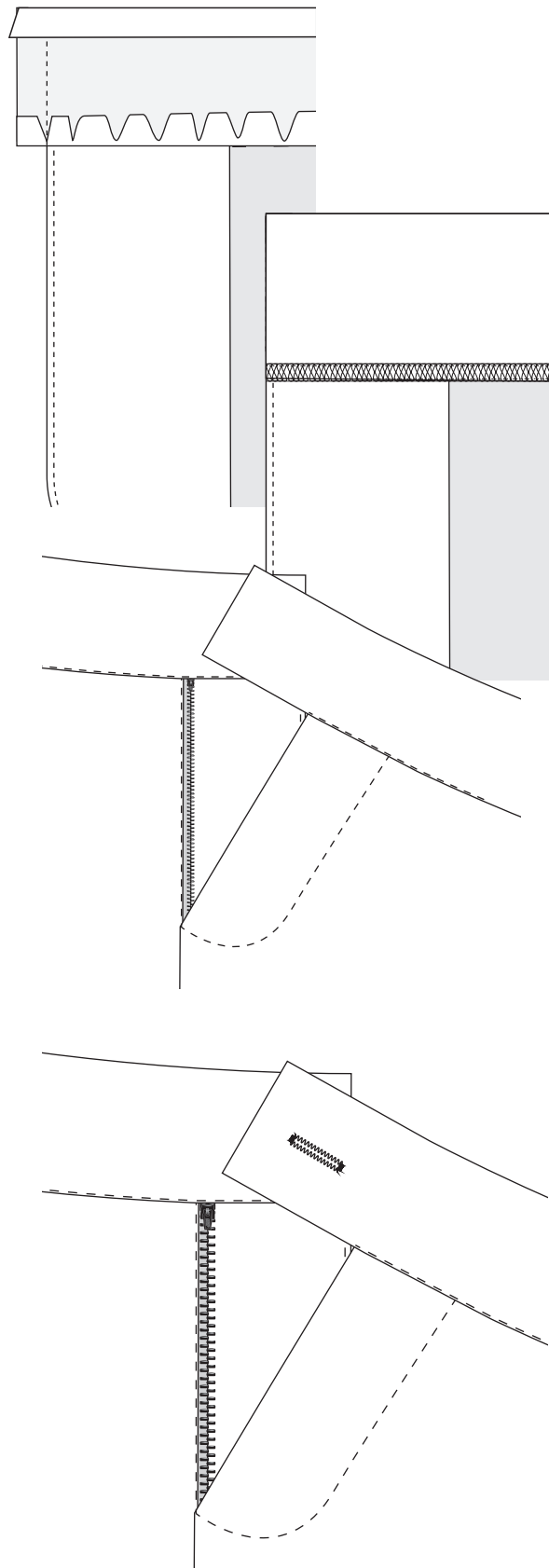

Button

1. Make sure your zipper is closed, then lay your waistband flat and mark with chalk or pen the middle opening of the buttonhole on the waistband underneath. This is your button placement.
2. Stitch on your button.
3. If using a pant hook and eye closure, lay your waistband flat and follow the instructions on the back of the hook and eye packaging.

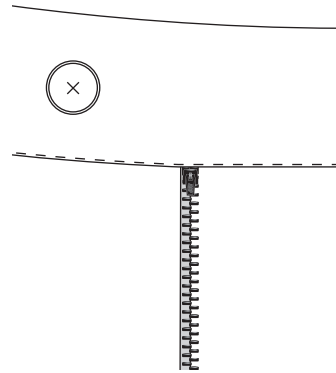

Hems

1. Fold up the pant seam allowance by 1/4" and press flat. Use pins if you need.
2. Fold up the pant seam allowance again by 1" and pin in place. Press.
3. Edge stitch 1/16" from edge along the hem edge to secure. You can also use a hand hemming stitch if you don't want your top stitching to be obvious.
4. Give your hems once last press and your done!

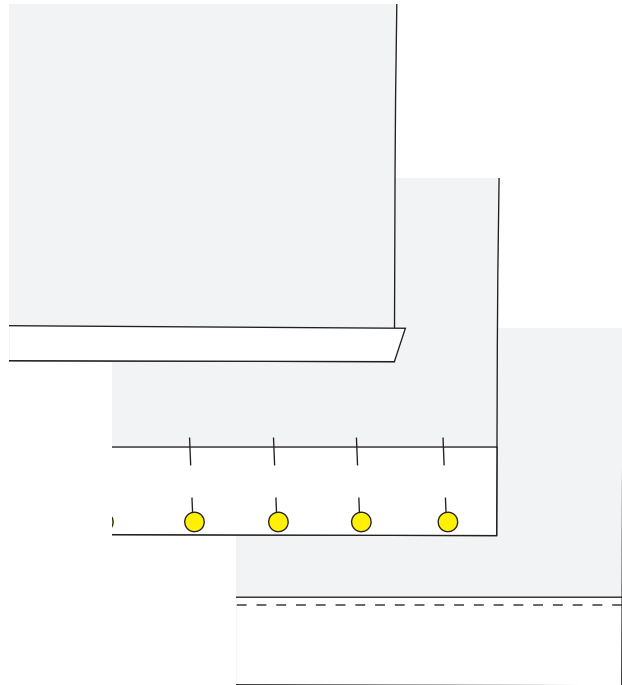

Guess who has a brand new pair of pants? Hopefully you but if you find anything wrong with this pattern, please let me know at

2" x 2"

TEST SQUARE

Measure this square to
make sure your scale is correct.
You will make one funky garment
if its not- heads up!

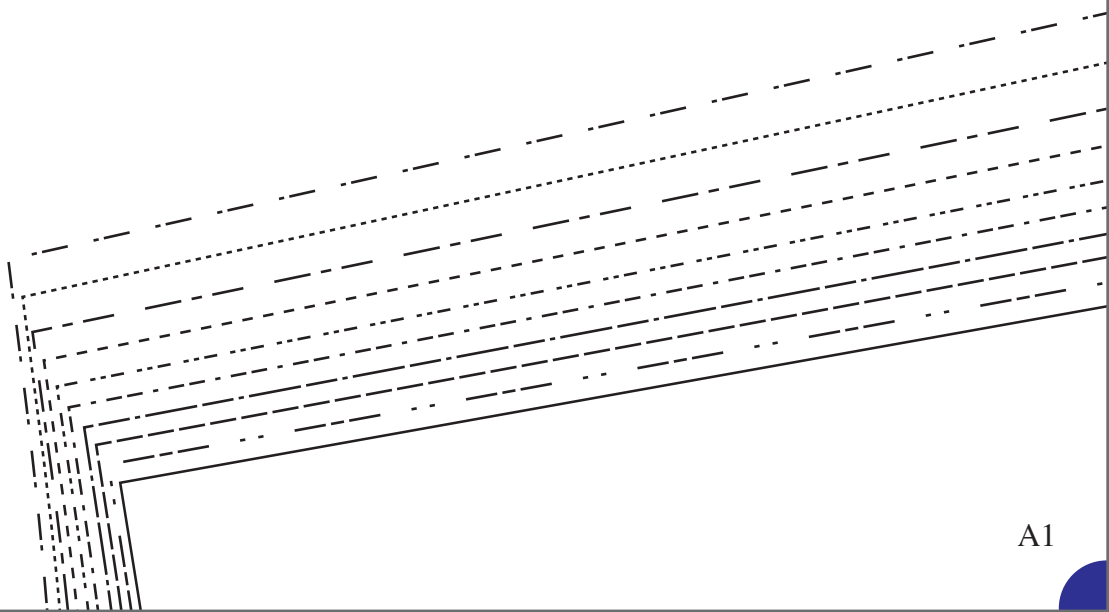

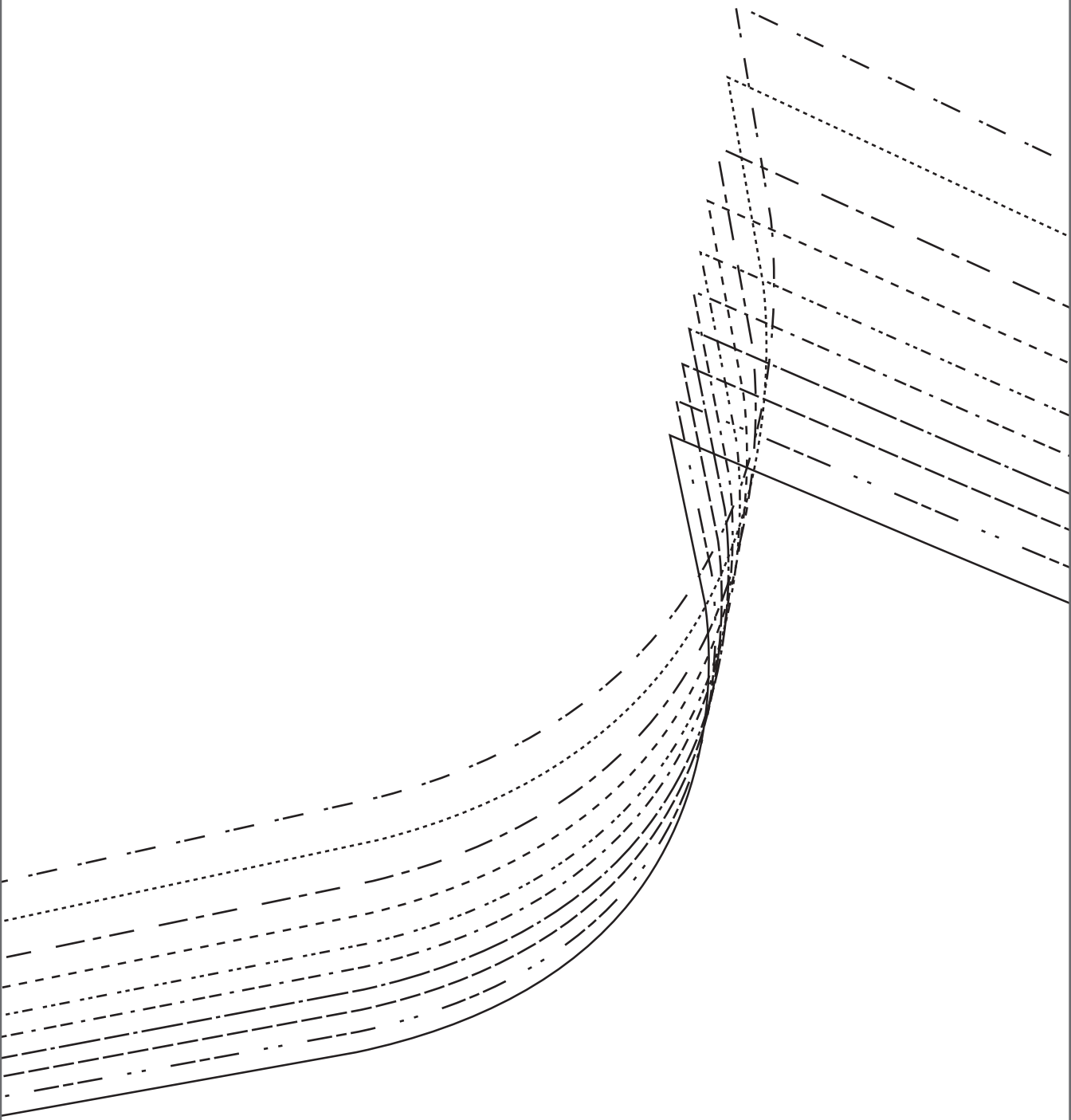

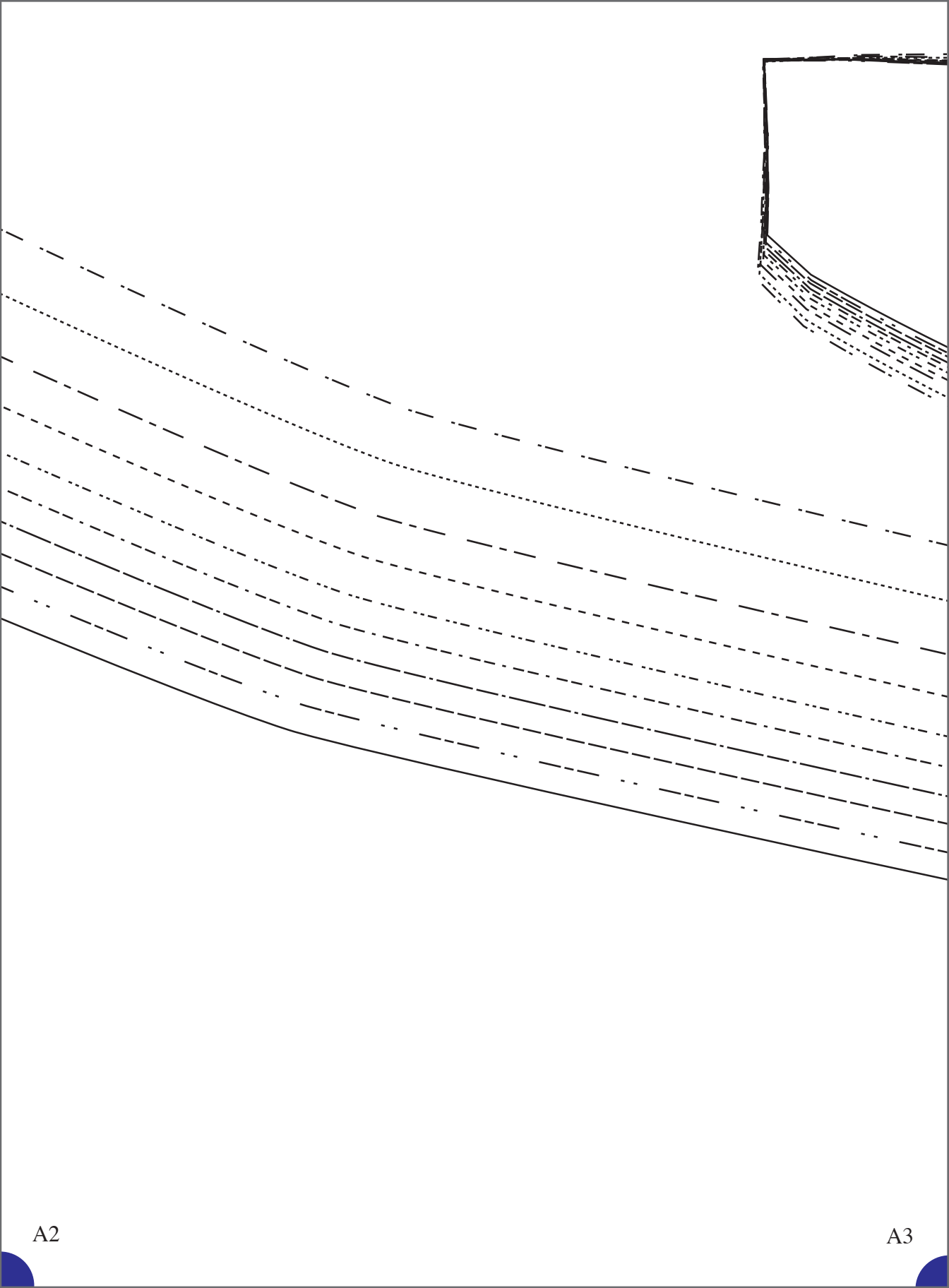

EMMA PANT

FRONT FACE BAG (6)

Sizes 0-18

Main Fabric: Cut 2

Interfacing: Cut 2

5/8" SEAM

ALLOWANCE

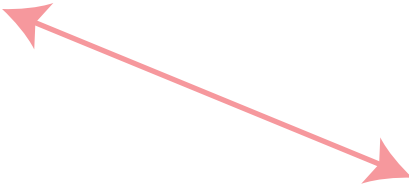

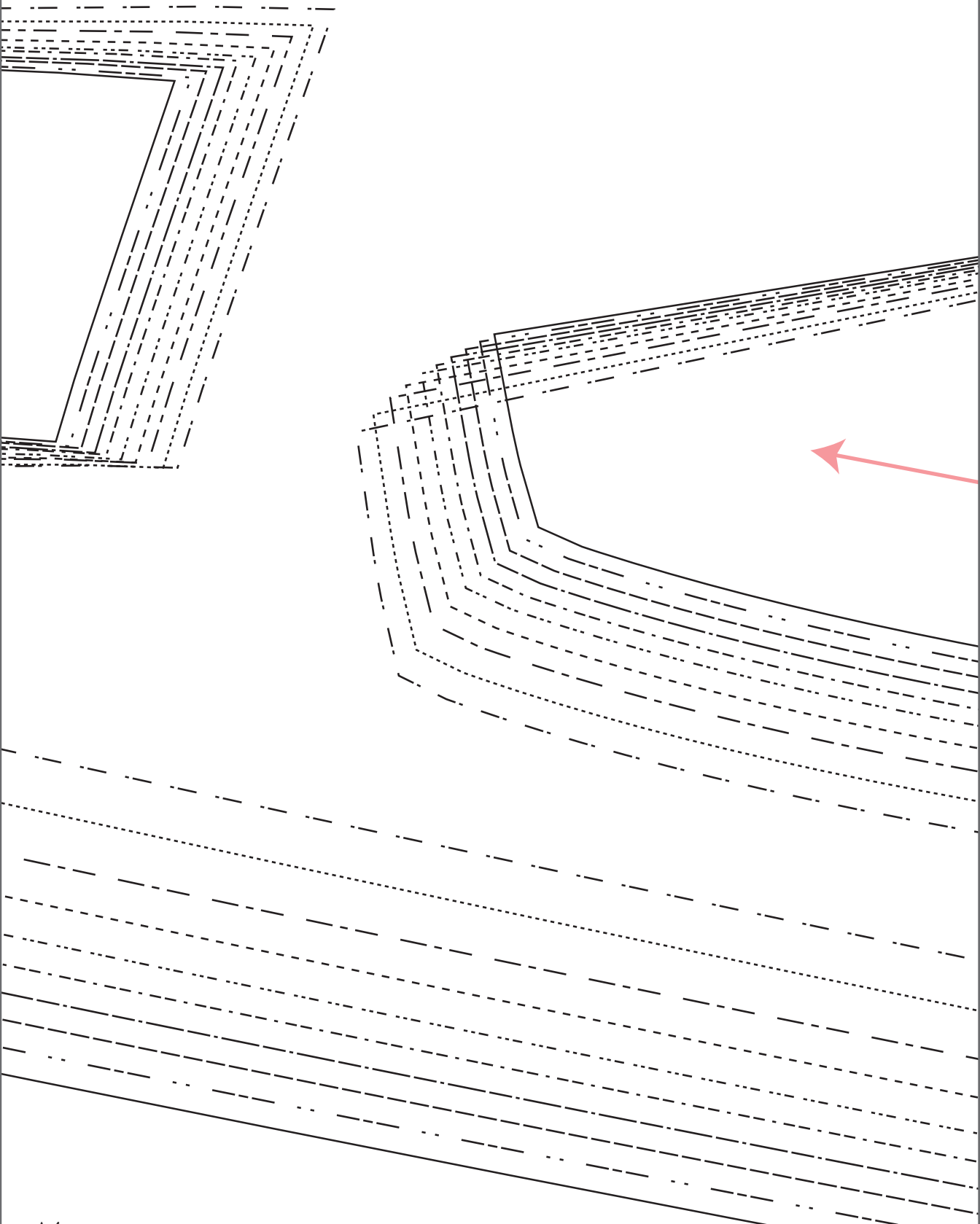

A4

A5

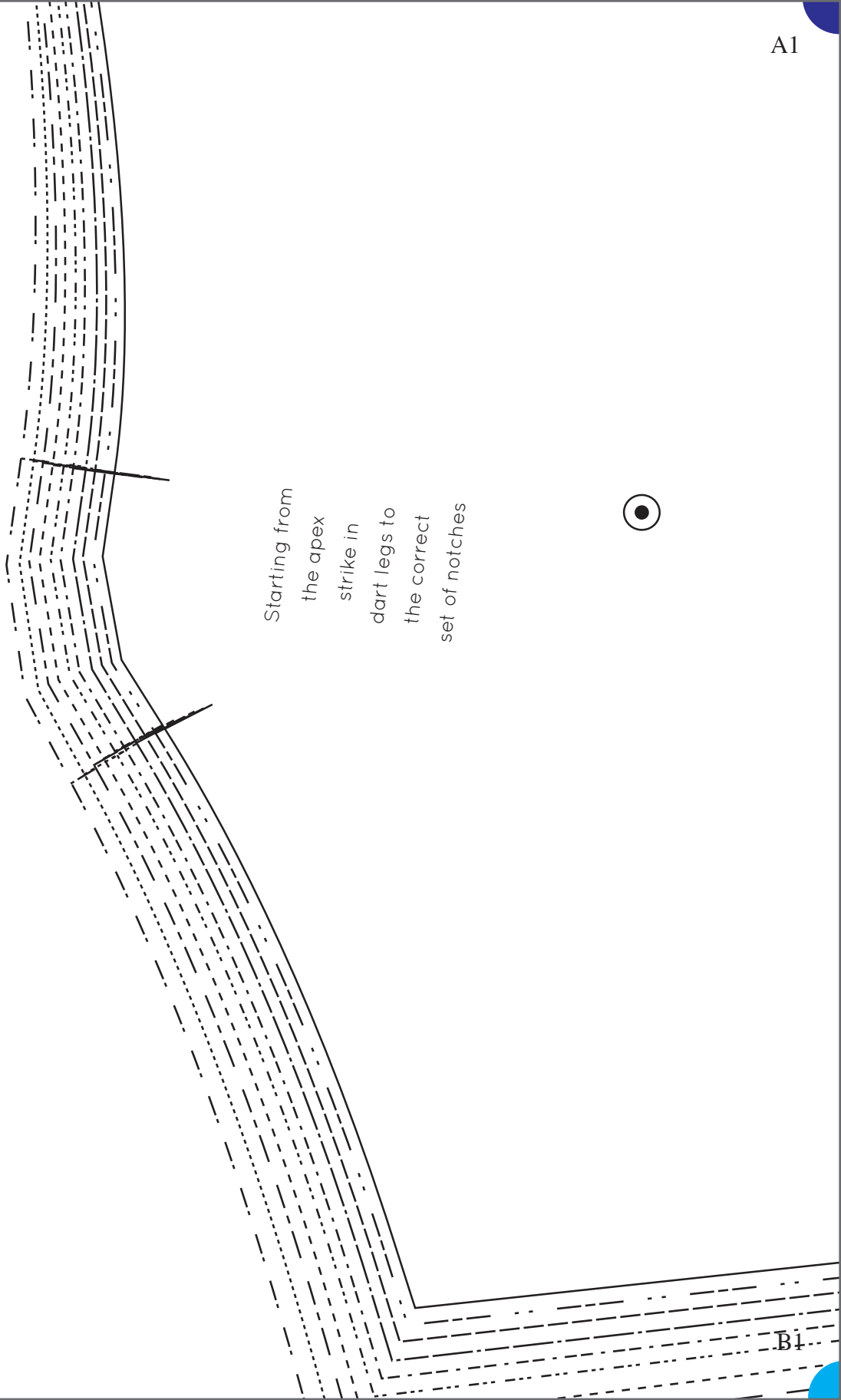

Starting from
the apex
strike in
dart legs to
the correct
set of notches



EMMA PANT
BACK PANT (2)

Sizes 0-18

Main Fabric: Cut 2

5/8" SEAM ALLOWANCE
EXCEPT AT HEM

0

A2

A3

2
4
6
8
10
12
14
16
18



B2

B3

A3

A4

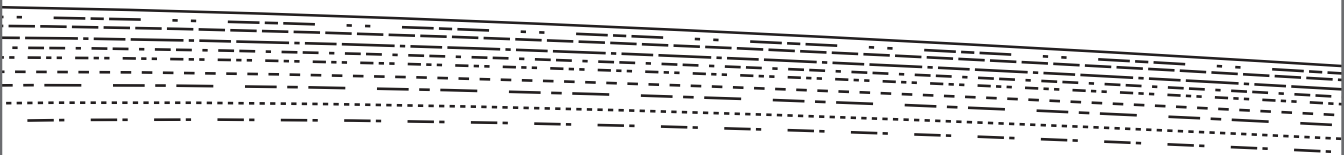
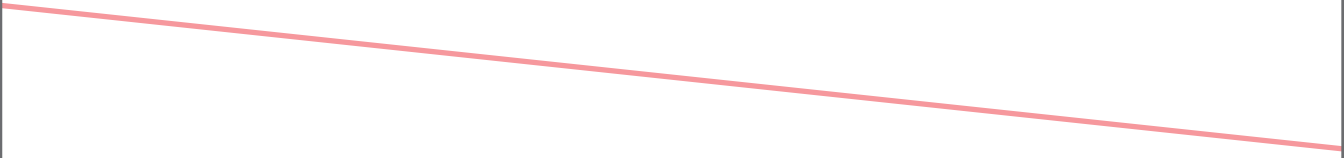

B3

B4

A4

A5

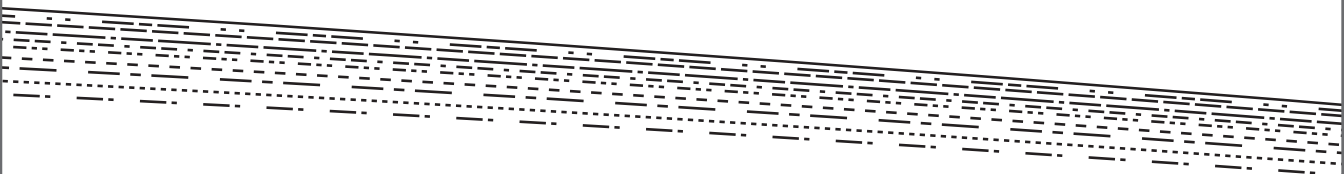
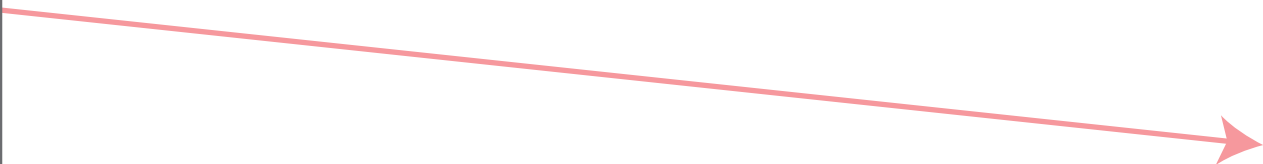

B4

B5

B1

C1

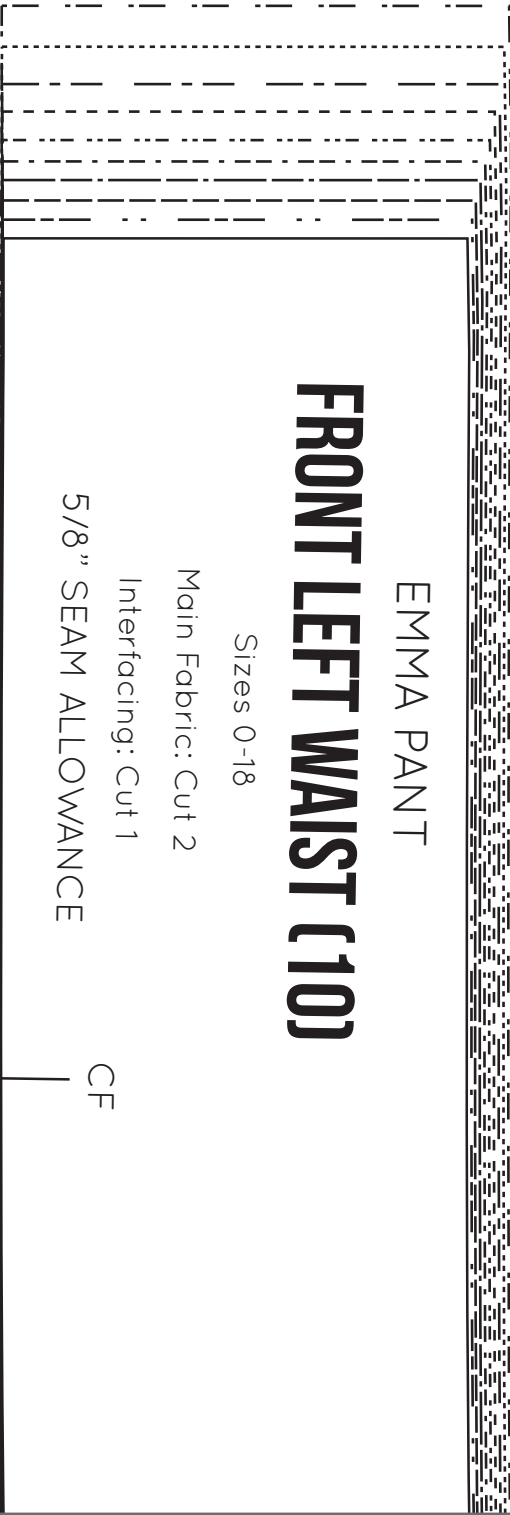

EMMA PANT

FRONT LEFT WAIST (10)

Sizes 0-18

Main Fabric: Cut 2

Interfacing: Cut 1

5/8" SEAM ALLOWANCE

CF

B1

B2



1 1/4" HEM ALLOWANCE



C1

C2

B2

B3

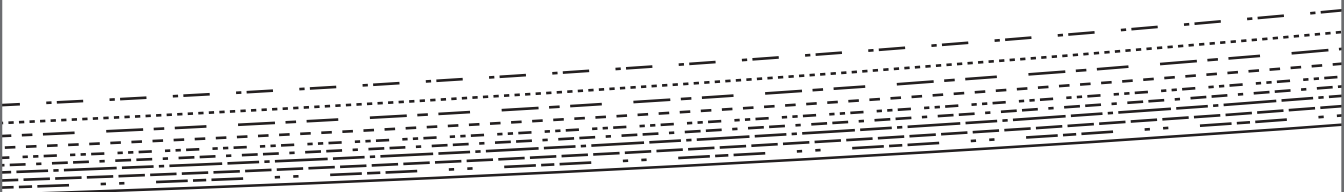

C2

C3

B3

B4

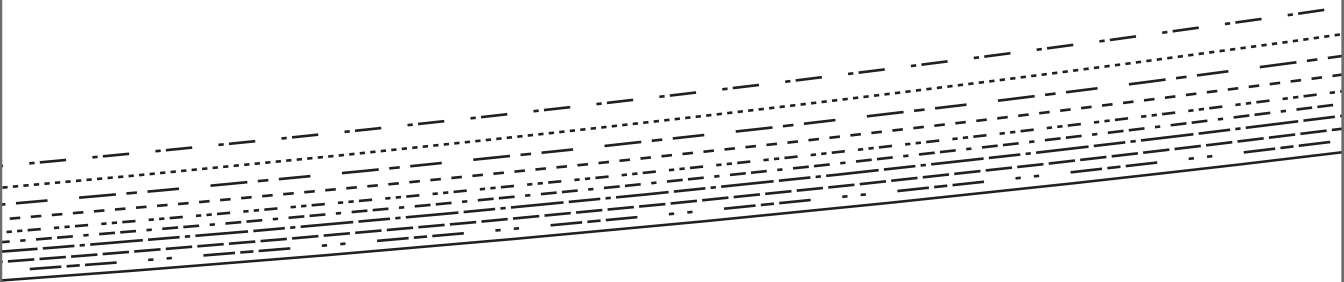

C3

C4

FRONT PANT (1)

Sizes 0-18

Main Fabric: Cut 2

5/8" SEAM ALLOWANCE

EXCEPT AT HEM

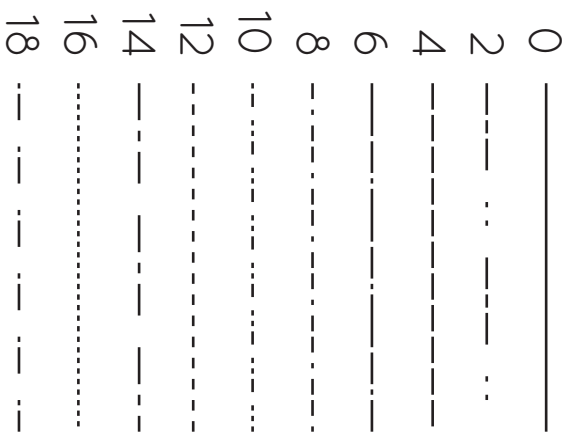

B5

B4

C5

C4

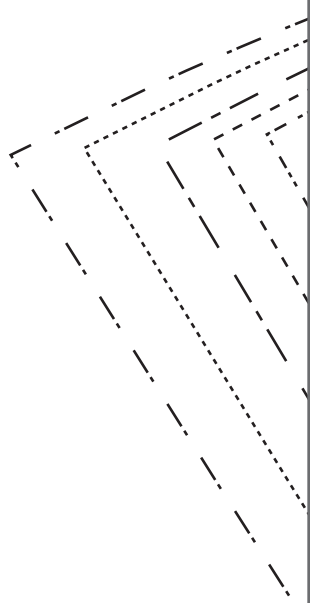
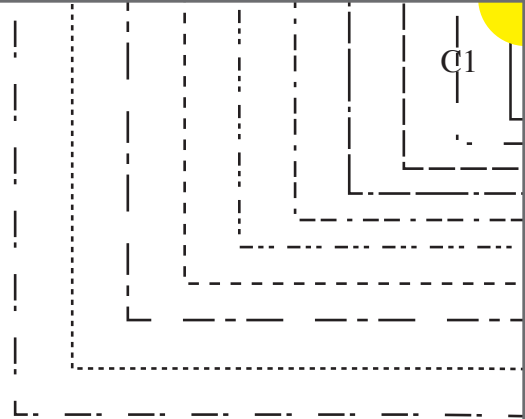
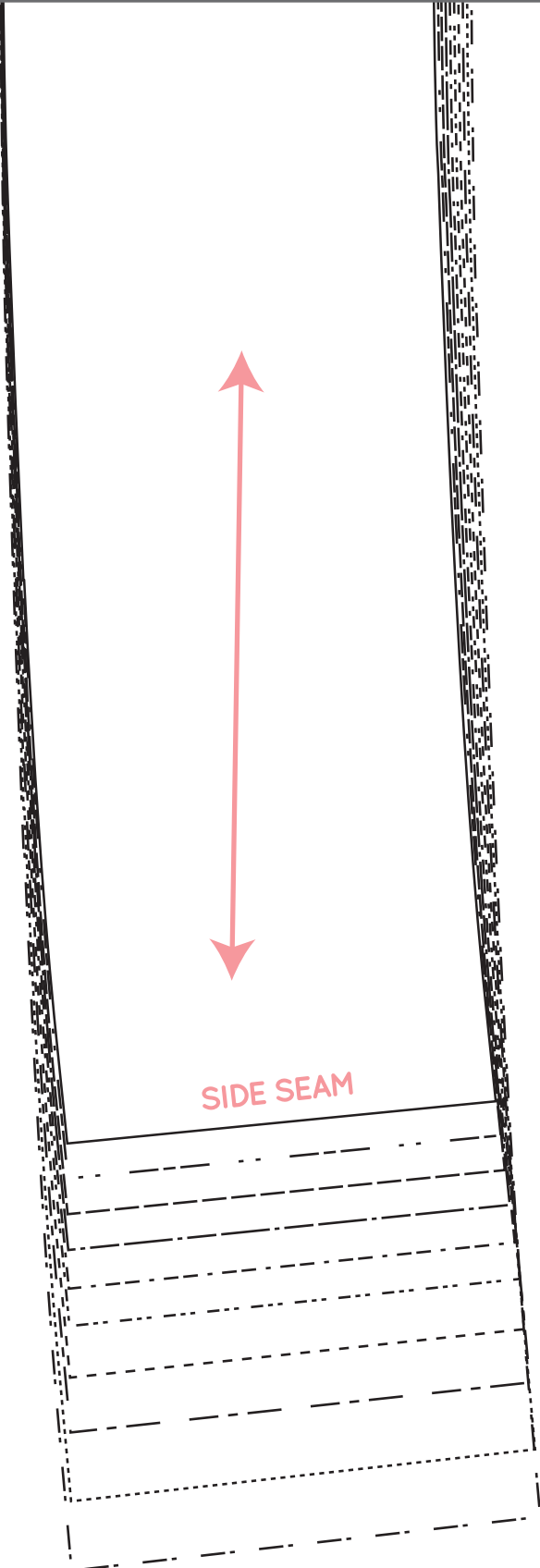

C1

C2

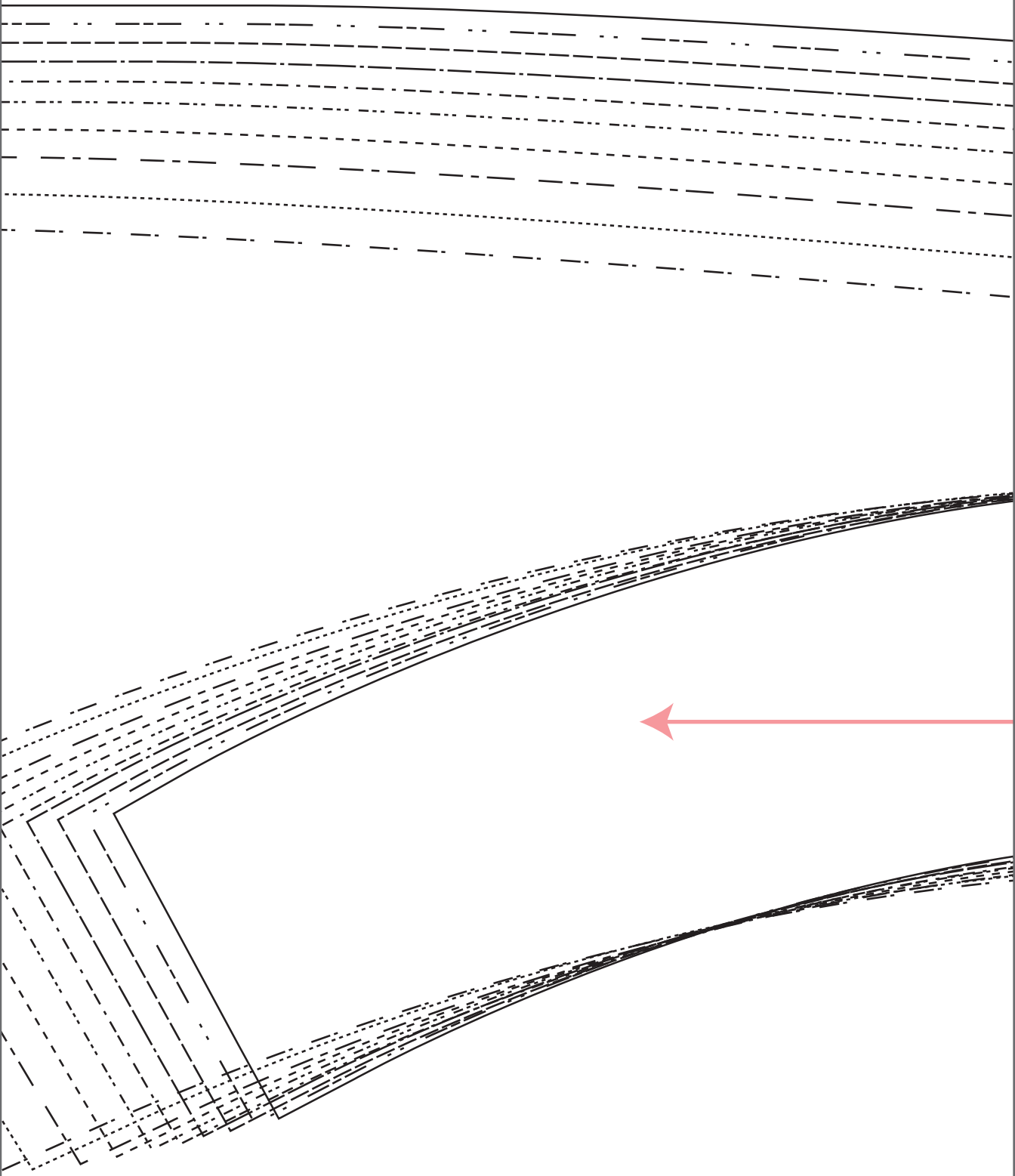

D1

D2

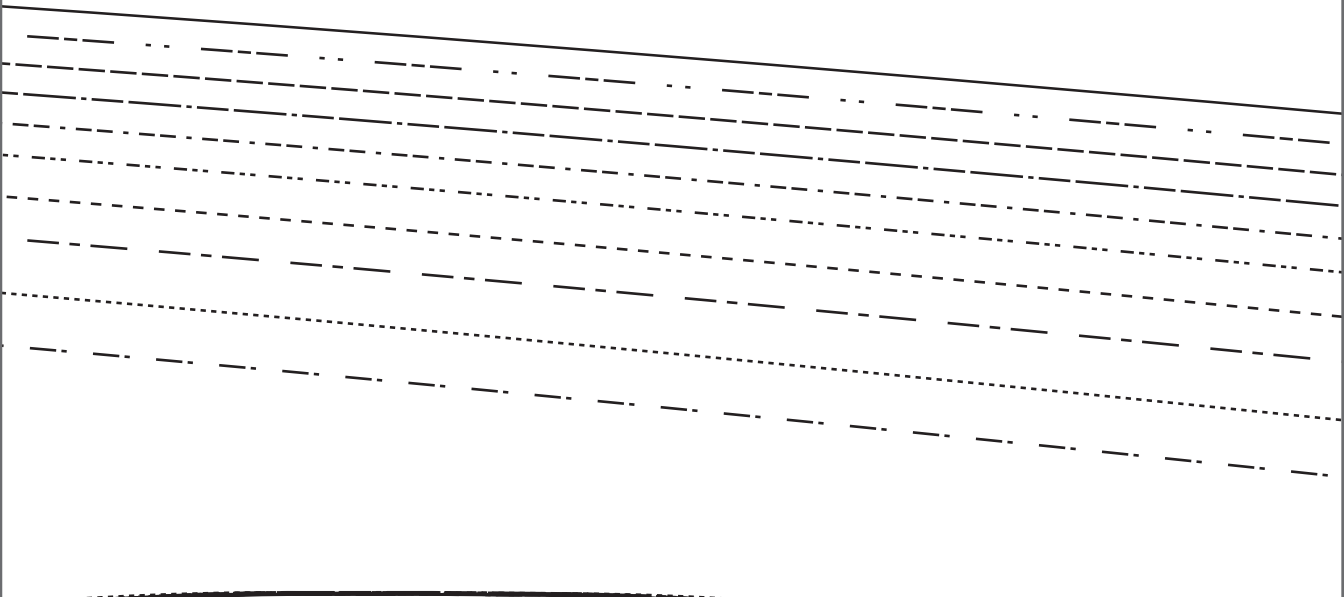

CB

5/8" SEAM ALLOWANCE

Interfacing: Cut 1

Main Fabric: Cut 2

Sizes 0-18

BACK WAIST (9)

EMMA PANT



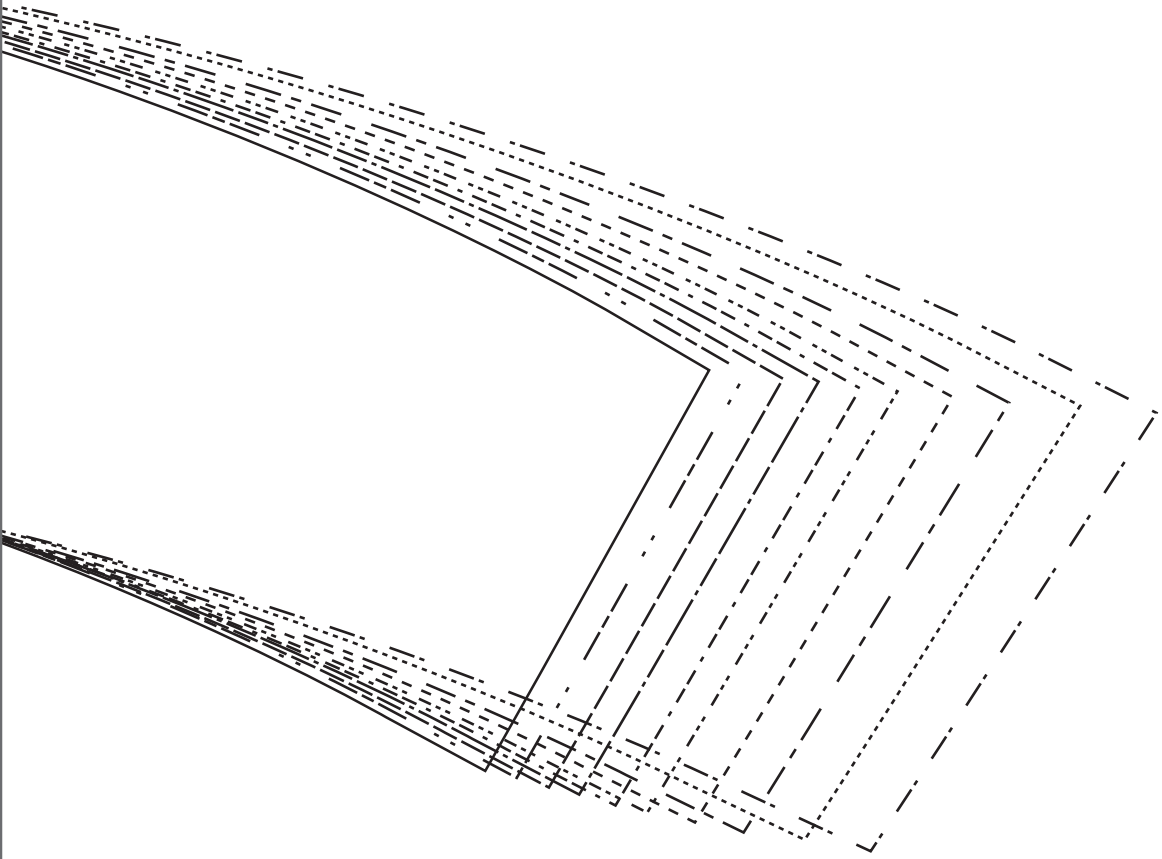
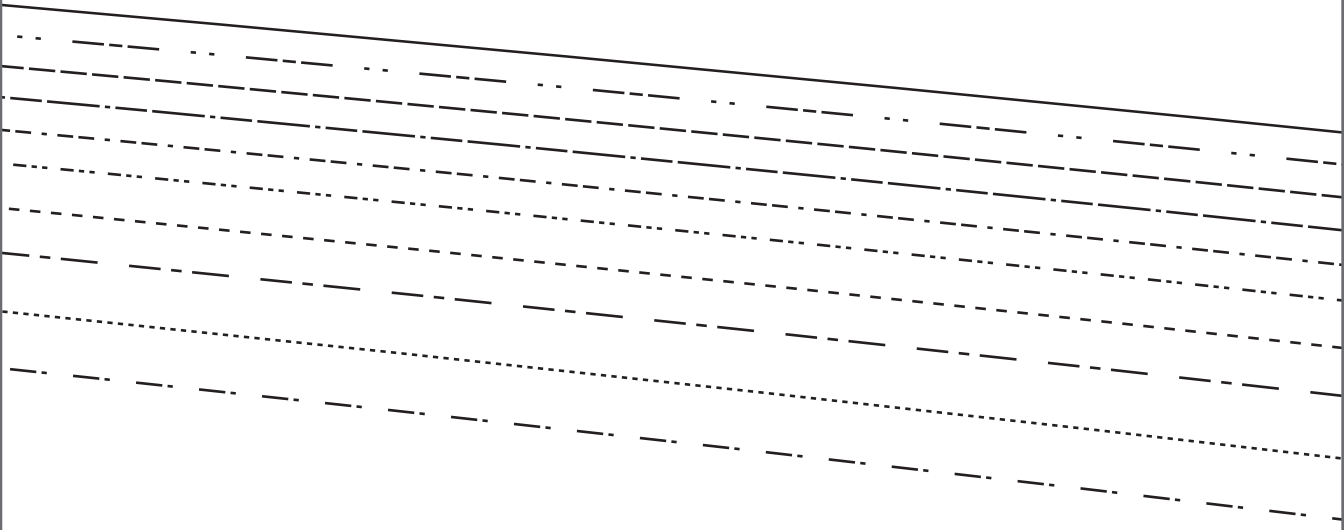

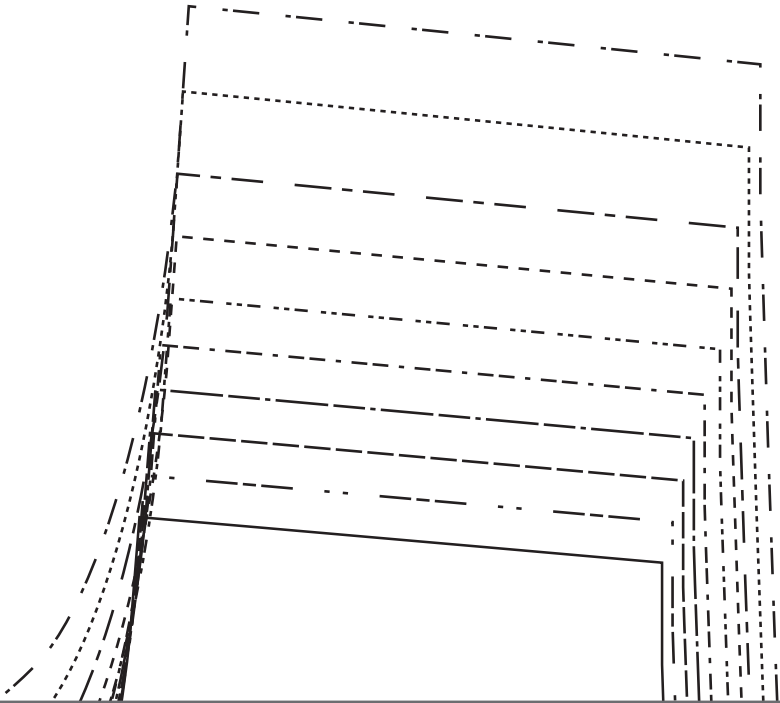
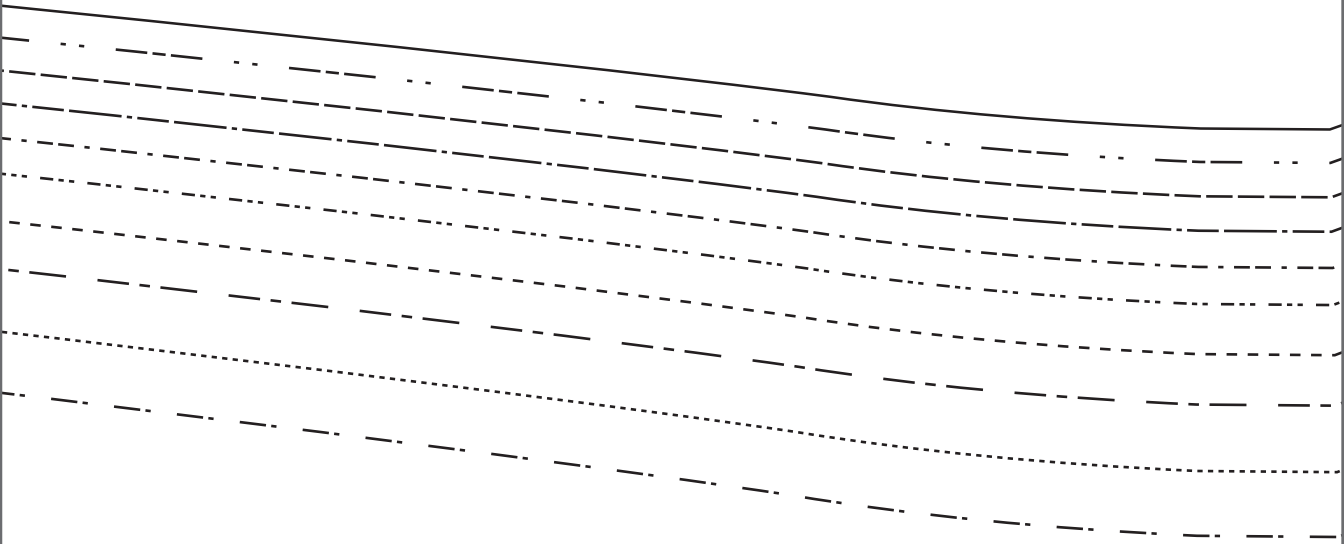

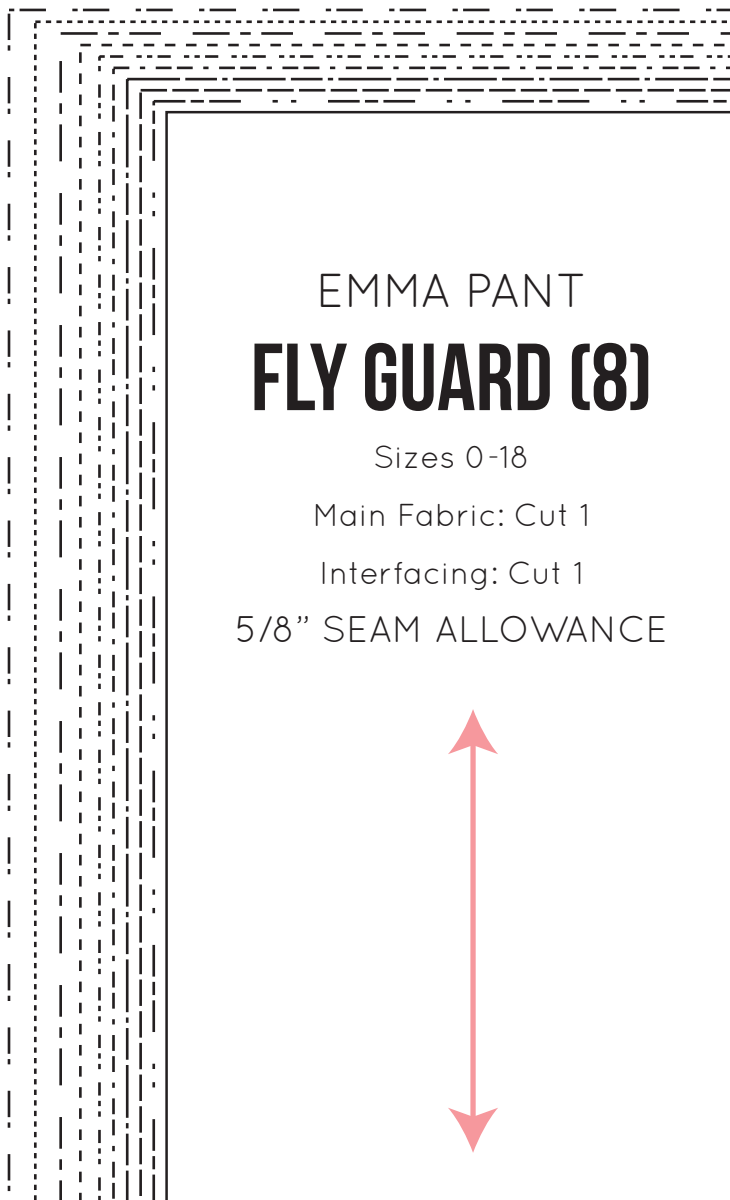

EMMA PANT

FLY GUARD (8)

Sizes 0-18

Main Fabric: Cut 1

Interfacing: Cut 1

5/8" SEAM ALLOWANCE



EMMA PANT

FLY (7)

Sizes 0-18

Main Fabric: Cut 2

Interfacing: Cut 1

5/8" SEAM ALLOWANCE

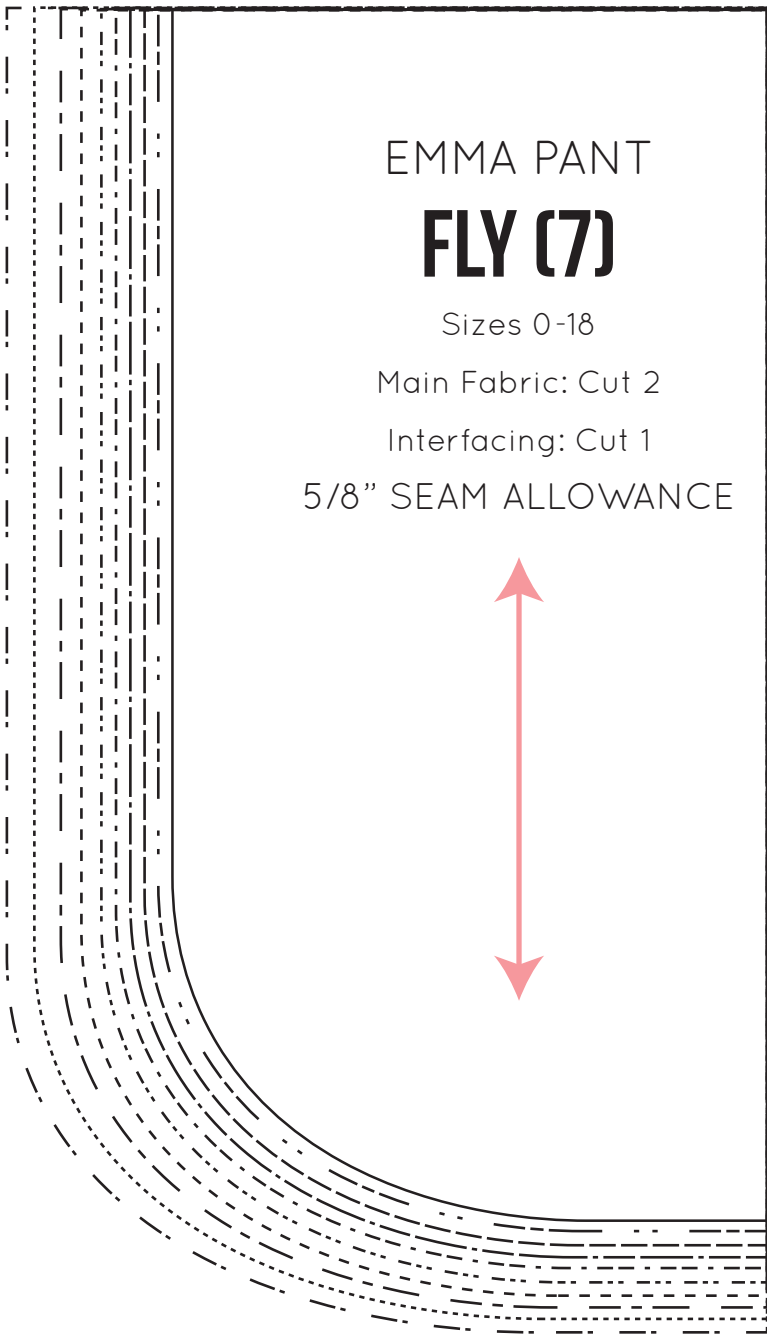

EMMA PANT

BACK BAG (3)

Sizes 0-18

Lining Fabric: Cut 2

5/8" SEAM ALLOWANCE

- 0 _____
- 2 - - - - -
- 4 - - - - -
- 6 - - - - -
- 8 - - - - -
- 10 - - - - -
- 12 - - - - -
- 14 - - - - -
- 16 - - - - -
- 18 - - - - -

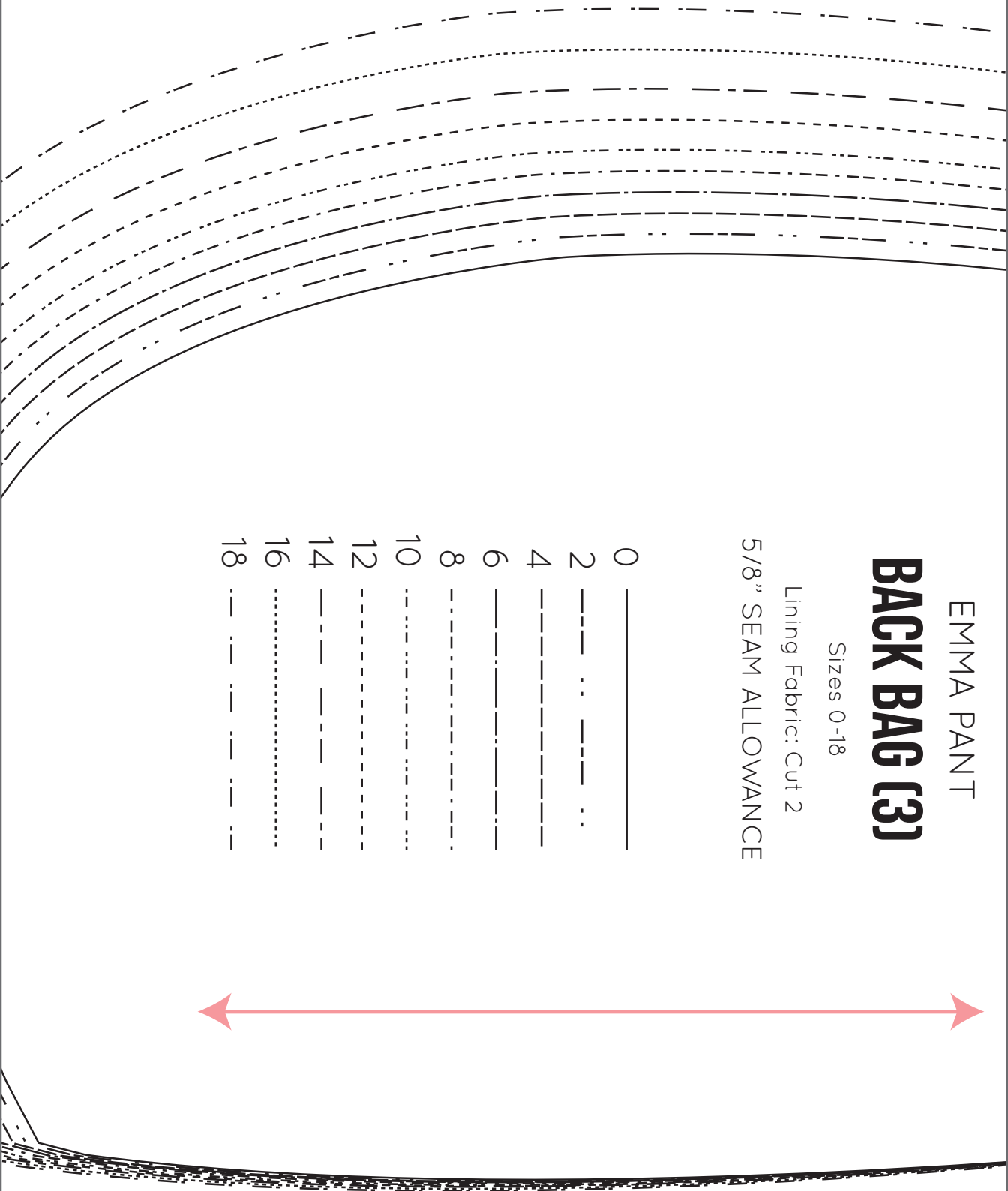

D3

D4

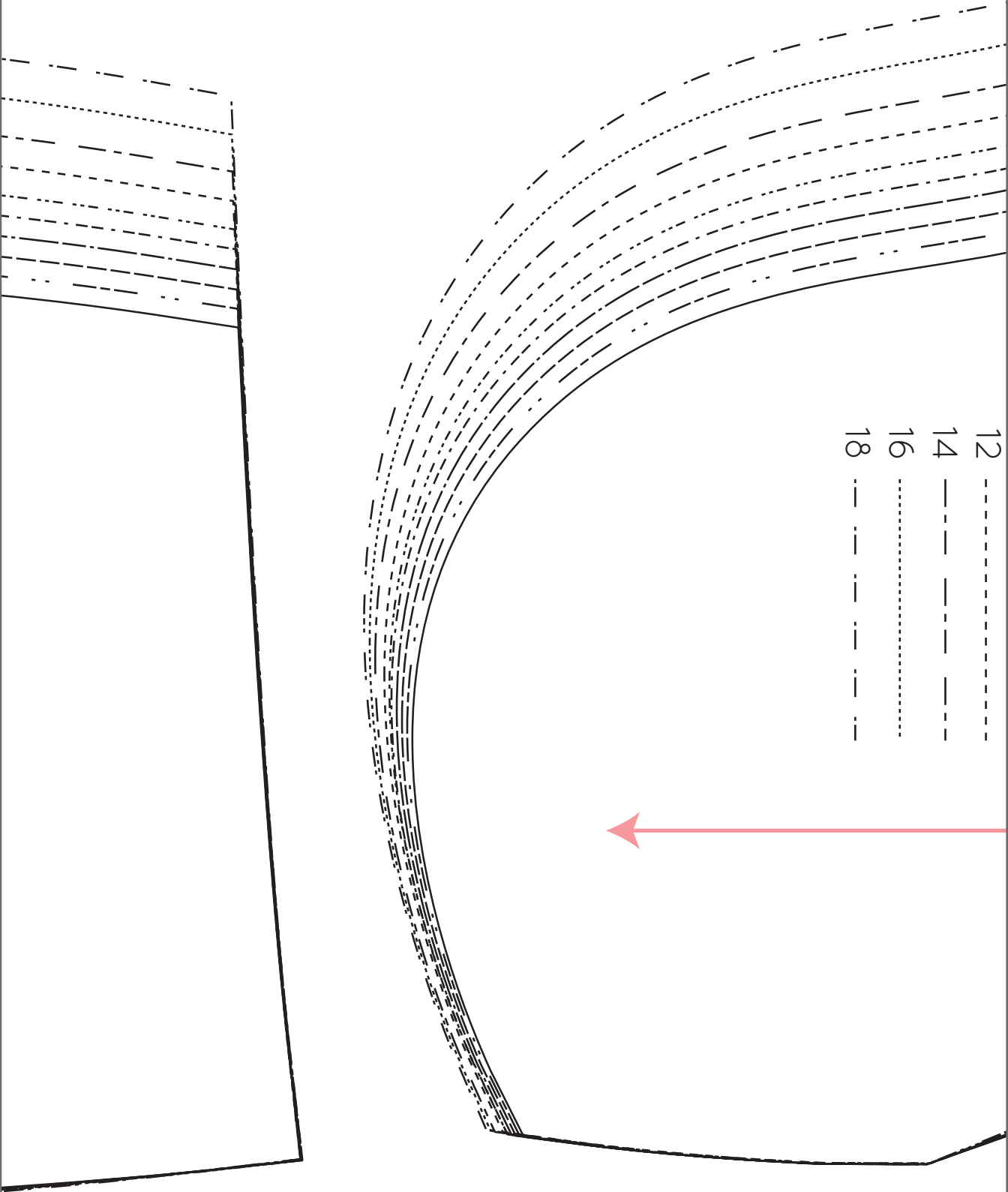

- 12 ———
- 14 - - - -
- 16 ······
- 18 - · - ·

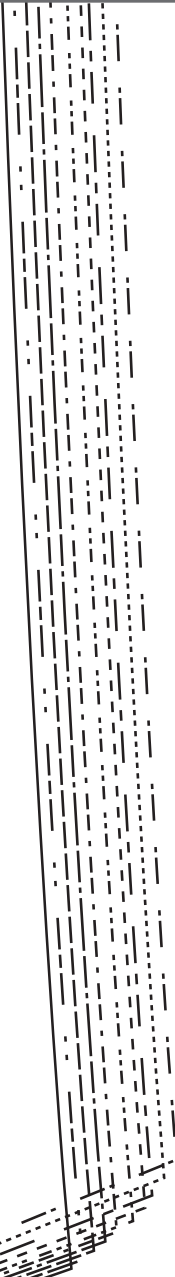

EMMA PANT

FRONT BAG (5)

Sizes 0-18

Lining Fabric: Cut 2

5/8" SEAM ALLOWANCE

0 _____

2 - - - - -

4 - - - - -

6 - - - - -

8 - - - - -

10 - - - - -

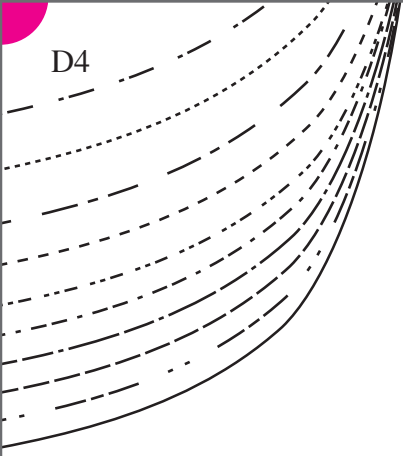

EMMA PANT

BACK FACE BAG (4)

Sizes 0-18

Main Fabric: Cut 2

5/8" SEAM ALLOWANCE



A5

1 1/4" HEM ALLOWANCE

B5

B5

FLY
NOTCH

FLY
NOTCH

C5

C5

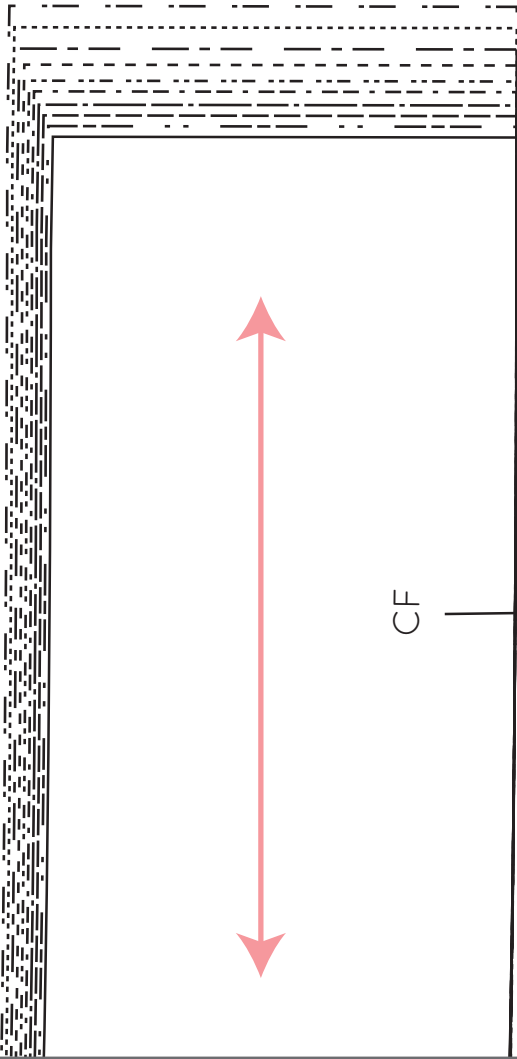
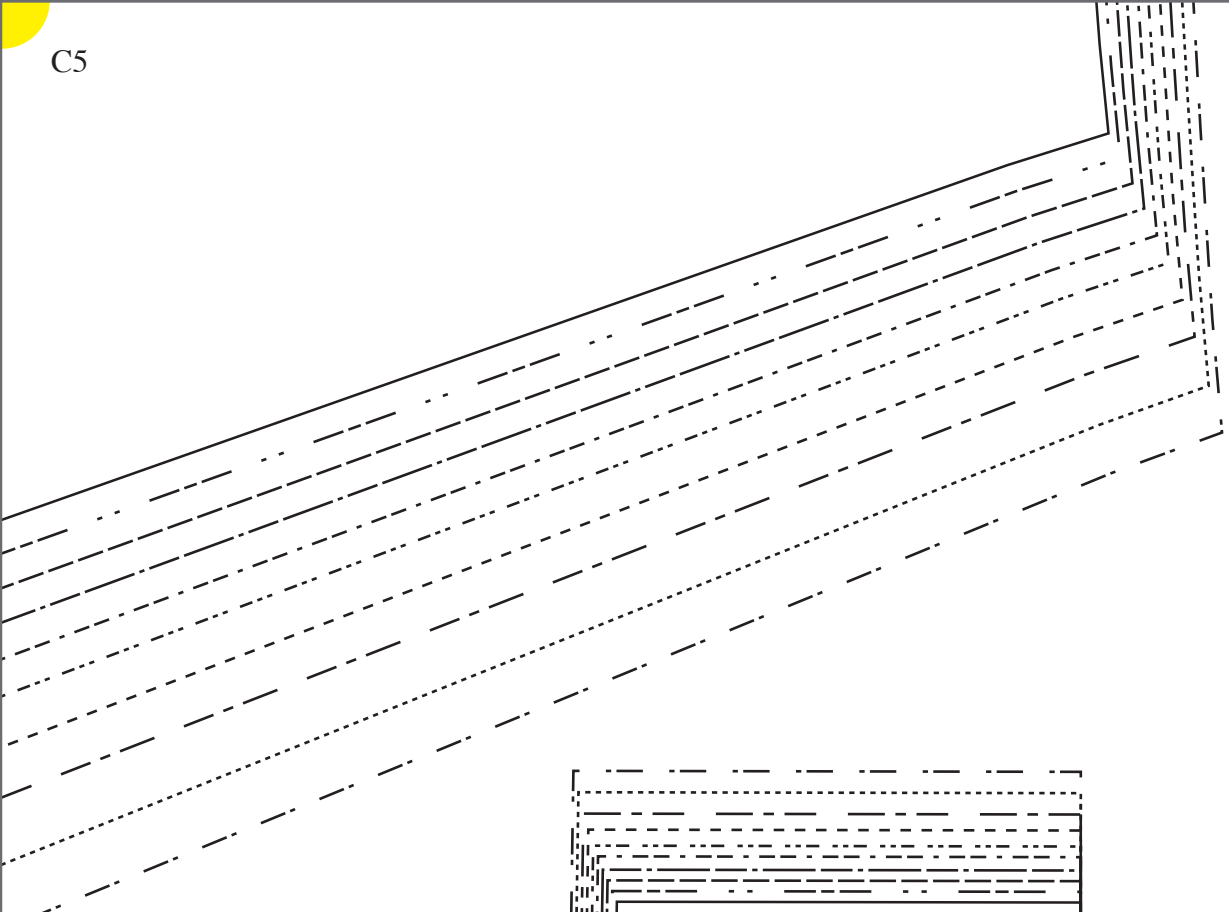

D5

EMMA PANT

FRONT RIGHT WAIST (11)

Sizes 0-18

Main Fabric: Cut 2

Interfacing: Cut 1

5/8" SEAM ALLOWANCE

SIDE SEAM

